

# Electro Streak ARF

## INSTRUCTION MANUAL



**Wingspan:** 44.5 in [1130mm]  
**Wing Area:** 342 sq in [22.03 dm<sup>2</sup>]  
**Weight:** 43 oz. [1218g]  
**Wing Loading:** 18.1 oz/sq ft [55.1 g/dm<sup>2</sup>]  
**Length:** 39.5 in [1003mm]  
**Radio:** 4-ch with 3 sub micro servos  
**Motor:** 600 size  
**Motor Battery:** 8.4 volt 2000mAh – 3000mAh

### WARRANTY

Great Planes® Model Manufacturing Co. guarantees this kit to be free from defects in both material and workmanship at the date of purchase. This warranty does not cover any component parts damaged by use or modification. **In no case shall Great Planes' liability exceed the original cost of the purchased kit.** Further, Great Planes reserves the right to change or modify this warranty without notice.

In that Great Planes has no control over the final assembly or material used for final assembly, no liability shall be assumed nor accepted for any damage resulting from the use by the user of the final user-assembled product. By the act of using the user-assembled product, the user accepts all resulting liability.

**If the buyer is not prepared to accept the liability associated with the use of this product, the buyer is advised to return this kit immediately in new and unused condition to the place of purchase.**

**READ THROUGH THIS MANUAL BEFORE STARTING CONSTRUCTION. IT CONTAINS IMPORTANT INSTRUCTIONS AND WARNINGS CONCERNING THE ASSEMBLY AND USE OF THIS MODEL.**



1610 Interstate Drive Champaign, IL 61822  
(217) 398-8970, Ext. 2  
airsupport@greatplanes.com

## TABLE OF CONTENTS

INTRODUCTION .....	2
SAFETY PRECAUTIONS .....	2
DECISIONS YOU MUST MAKE .....	3
Radio Equipment .....	3
Battery Selection .....	3
Chargers.....	3
<b>ADDITIONAL ITEMS REQUIRED .....</b>	<b>4</b>
Adhesives & Building Supplies.....	4
Optional Supplies & Tools .....	4
<b>IMPORTANT BUILDING NOTES.....</b>	<b>4</b>
<b>ORDERING REPLACEMENT PARTS.....</b>	<b>5</b>
<b>METRIC CONVERSIONS .....</b>	<b>5</b>
<b>METRIC/INCH RULER .....</b>	<b>5</b>
<b>KIT CONTENTS.....</b>	<b>6</b>
<b>PREPARATIONS .....</b>	<b>7</b>
<b>BUILD THE WING .....</b>	<b>7</b>
Install the Ailerons .....	7
Join the Wing .....	8
<b>ASSEMBLE THE FUSELAGE.....</b>	<b>9</b>
Mount the Wing .....	9
Mount the Stab & Fin .....	9
Install Servo & Battery Tray .....	11
Install the Motor & Speed Control .....	12
Install the Elevator .....	13
Install the Rudder .....	14
<b>RADIO SET-UP .....</b>	<b>15</b>
<b>ASSEMBLE &amp; INSTALL THE FOLDING PROPELLER .....</b>	<b>16</b>
Battery Installation .....	16
<b>GET THE MODEL READY TO FLY .....</b>	<b>17</b>
Check the Control Directions .....	17
Set the Control Throws.....	17
Balance the Model (C.G.).....	18
Balance the Model Laterally.....	18
<b>PREFLIGHT .....</b>	<b>18</b>
Identify Your Model .....	18
Charge the Batteries .....	19
<b>PROPER CARE OF YOUR MOTOR .....</b>	<b>19</b>
<b>PERFORMANCE TIPS .....</b>	<b>19</b>
Ground Check .....	19
Range Check .....	19
<b>AMA SAFETY CODE (excerpt) .....</b>	<b>19</b>
<b>CHECK LIST .....</b>	<b>20</b>
<b>FLYING.....</b>	<b>20</b>
Takeoff .....	20
Flight.....	20
Landing.....	21
<b>FLIGHT LOG .....</b>	<b>23</b>

## INTRODUCTION

The ElectroStreak™ ARF has been a favorite among pilots since 1988. Many pilots began flying electrics with the ElectroStreak. Over the years, there have been many advancements in electronics such as high frequency electronic speed controls and 3000mAh nickel-metal hydride motor batteries. The original ElectroStreak was an all wood kit. The ElectroStreak ARF comes as a high quality

fiberglass fuselage with a built-up wing and tail, motor, folding prop and electronic speed control. You can be in the air within hours after opening the box instead of spending weeks or months building and covering the plane.

For the latest technical updates or manual corrections for the ElectroStreak ARF, visit the web site listed below and select the Great Planes ElectroStreak ARF. A “tech notice” box will appear in the upper left corner of the page if there is new technical information or changes to this kit.

<http://www.greatplanes.com/airplanes/index.html>

## PROTECT YOUR MODEL, YOURSELF & OTHERS...FOLLOW THESE IMPORTANT SAFETY PRECAUTIONS

1. Your ElectroStreak ARF should not be considered a toy, but rather a sophisticated, working model that functions very much like a full-size airplane. Because of its performance capabilities, the ElectroStreak ARF, if not assembled and operated correctly, could possibly cause injury to you or spectators and damage to property.
2. You must assemble the model **according to the instructions**. Do not alter or modify the model, as doing so may result in an unsafe or unflyable model. In a few cases the instructions may differ slightly from the photos. In those instances the written instructions should be considered as correct.
3. You must take time to **build straight, true and strong**.
4. You must use an R/C radio system that is in first-class condition with the appropriate size servos.
5. You must correctly install all R/C and other components so that the model operates correctly on the ground and in the air.
6. You must check the operation of the model before **every** flight to insure that all equipment is operating and that the model has remained structurally sound. Be sure to check clevises or other connectors often and replace them if they show any signs of wear or fatigue.
7. If you are not already an experienced R/C pilot, you should fly the model only with the help of a competent, experienced R/C pilot.
8. While this kit has been flight tested to exceed normal use, if the plane will be used for extremely high stress flying, such as racing, the modeler is responsible for taking steps to reinforce the high stress points.

We, as the kit manufacturer, provide you with a top quality kit and instructions, but ultimately the quality and flyability of your finished model depends on how you build it; therefore, we cannot in any way guarantee the performance of your completed model, and no representations are expressed or implied as to the performance or safety of your completed model.

**Remember: Take your time and follow the instructions to end up with a well-built model that is straight and true.**

If you have not flown this type of model before, we recommend that you get the assistance of an experienced pilot in your R/C club for your first flights. If you're not a member of a club, your local hobby shop has information about clubs in your area whose membership includes experienced pilots.

In addition to joining an R/C club, we strongly recommend you join the AMA (Academy of Model Aeronautics). AMA membership is required to fly at AMA sanctioned clubs. There are over 2,500 AMA chartered clubs across the country. Among other benefits, the AMA provides insurance to its members who fly at sanctioned sites and events. Additionally, training programs and instructors are available at AMA club sites to help you get started the right way. Contact the AMA at the address or toll-free phone number below:



**Academy of Model Aeronautics**

5151 East Memorial Drive  
Muncie, IN 47302-9252  
Tele. (800) 435-9262  
Fax (765) 741-0057

Or via the Internet at: <http://www.modelaircraft.org>

**DECISIONS YOU MUST MAKE**

This is a partial list of items required to finish the ElectroStreak ARF that may require planning or decision making before starting to build. Order numbers are provided in parentheses.

**Radio Equipment**

A 4-channel radio system with 3 micro servos is required. Servos that measure 1" [25.4mm] long by 1" [25.4mm] high by 1/2" [12.7mm] wide with at least 15 oz. of torque are recommended. The Futaba® S3101 will work well in the ElectroStreak ARF. Two 12" servo extensions are also required for the electronic speed control and the aileron servo.

**Battery Selection**

The ElectroStreak ARF was designed to fly on a 7-cell 8.4 volt 1700 – 3000 mAh flat battery pack. Even though the ElectroStreak ARF will fly well on an inexpensive battery pack, we recommend a battery pack that uses Sanyo® or

Panasonic® cells. These cells have a low internal resistance, which translates into more power and less heat.

If you are new to electric airplanes, here is a short explanation of rechargeable NiCd (Nickel Cadmium) and NiMH (Nickel-Metal Hydride) batteries. A single cell rechargeable battery supplies 1.2 volts with no load (not powering anything). A 7-cell battery pack can supply 8.4 volts (1.2 volts x 7 cells = 8.4 volts). The cell rating in mAh (milli-amp-hours) is the amount of current the battery can supply. If a battery is rated at 1700 mAh, the battery can supply 1.7 amps for 1 hour. This sounds great, flying for an hour on a single battery charge! The bad news is that to produce the power needed to fly an airplane the size of the ElectroStreak ARF, the motor draws from 15-25 amps. The current consumption reduces the run time to 4-8 minutes. The good news is that propellers become more efficient as the speed of the plane increases. This lowers the current draw, allowing the plane to fly longer on a single charge, sometimes up to 20% longer. Also, with an electronic speed control, the motor can be throttled back, increasing the flight time. Most airplanes only need full throttle during takeoff and climbing maneuvers.

We recommend the use of high quality battery packs. The higher quality batteries usually have less internal resistance than the average battery. The higher quality battery will provide more power to the motor than the average battery. In rechargeable batteries, internal resistance transforms power into heat. With less internal resistance, there is more power available to the motor and less heat is generated. We hope this helps explain NiCd and NiMH batteries and why a high quality battery should be used in the ElectroStreak ARF.

**Chargers**

A fully charged battery pack will provide an initial "surge" of power during the first 15 to 30 seconds of the motor run. Then the power output stays fairly steady for the next several minutes before dropping off quickly. If you do not charge your battery completely, it will not deliver that surge necessary for a good takeoff and climb out. There are three easy ways to "peak-charge" your battery pack.

1. The easiest way is with a "peak-detecting" battery charger. This type of charger will automatically charge your battery until it is fully charged. The NiMH batteries require a peak-detecting charger that meets the specific charging needs of NiMH batteries.

2. The second method of charging your motor batteries is to monitor the voltage of your battery pack with a voltmeter. **This method is only recommended for NiCd batteries.** Your charger may have sockets into which you may plug a voltmeter. If not, you may insert the probes from the voltmeter into the rear of the battery plug, making contact with the metal contacts. As your battery charges, the voltage will gradually increase. When the battery is fully charged, the voltage will start to **drop**. At this point your battery is fully charged.

3. The third (and least reliable) method of peak-charging your battery pack is by checking its temperature. **This method is only recommended for NiCd batteries.** As the battery charges it will remain cool until it is fully charged. When it reaches the fully charged state, it will rapidly build up heat. You can feel this heat with your hand. As soon as the pack starts to noticeably warm up, disconnect it from the charger. **Do not continue charging if the battery pack is hot!** Overcharging will damage your battery pack and can result in an explosion.

**IMPORTANT: The ESC and motor are a matched pair. The use of a different ESC or motor may damage each other and void their warranties.**

## ADDITIONAL ITEMS REQUIRED

### Adhesives & Building Supplies

In addition to common household tools and hobby tools, this is the "short list" of the most important items required to build the ElectroStreak ARF. **Great Planes Pro™ CA and Epoxy glue are recommended.**

- 1/2 oz. Thin Pro CA (GPMR6001)
- 6-Minute epoxy (GPMR6045)
- 30-Minute epoxy (GPMR6047)
- Mixing sticks (GPMR8055)
- Great Planes Threadlocker™ (GPMR6060)
- Hobby knife (HCAR0105)
- #11 Blades (HCAR0211)
- Builder's triangle (HCAR0480)
- Electric drill and 1/16" [1.6mm], 3/32" [2.3mm], 1/8" [3.1mm], 1/4" [6.4mm] drill bits
- Small phillips screwdrivers
- Pliers with wire cutter (HCAR0630)
- 6-Piece standard ballwrench set (GPMR8008)
- Masking tape (TOPR8018)
- Denatured alcohol (for epoxy clean up)

### Optional Supplies & Tools

Here is a list of optional tools mentioned in the manual that will help you build the ElectroStreak ARF.

- Great Planes CG Machine™ (GPMR2400)
- Straightedge with scale (HCAR0475)
- CA Debonder (GPMR6039)
- CA Applicator tips (GPMR6033)
- Non-elastic monofilament or Kevlar™ fishing line (for stab alignment)
- Felt-tip marker (TOPQ2510)
- Great Planes AccuThrow™ Deflection Gauge (for measuring control throws, GPMR2405)
- Soldering iron (25 watt)

## IMPORTANT BUILDING NOTES

- There are two types of screws used in this kit:

**Sheet metal screws** are designated by a number and a length. **For example #6 x 3/4" [19mm].**

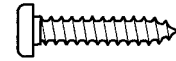

*This is a number six screw that is 3/4" [19mm] long.*

**Machine screws** are designated by a number, threads per inch, and a length. **For example 4-40 x 3/4" [19mm].**

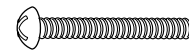

*This is a number four screw that is 3/4" [19mm] long with forty threads per inch.*

- When you see the term **test fit** in the instructions, it means that you should first position the part on the assembly **without using any glue**, then slightly modify or *custom fit* the part as necessary for the best fit.

- Whenever the term **glue** is written you should rely upon your experience to decide what type of glue to use. When a specific type of adhesive works best for that step, the instructions will make a recommendation.

- Whenever just **epoxy** is specified you may use **either** 30-minute (**or** 45-minute) epoxy **or** 6-minute epoxy. When 30-minute epoxy is specified it is **highly** recommended that you use only 30-minute (or 45-minute) epoxy, because you will need the working time and/or the additional strength.

- **Photos** and **sketches** are placed **before** the step they refer to. Frequently you can study photos in following steps to get another view of the same parts.

- The Great Planes ElectroStreak ARF is factory-covered with Top Flite® MonoKote® film. Should repairs ever be required, MonoKote can be patched with additional MonoKote purchased separately. MonoKote is packaged in six-foot rolls, but some hobby shops also sell it by the foot. If only a small piece of MonoKote is needed for a minor patch, perhaps a fellow modeler would give you some. MonoKote is applied with a model airplane covering iron, but in an emergency a regular iron could be used. A roll of MonoKote includes full instructions for application. Following are the colors used on this model and order numbers for six foot rolls.

White	TOPQ0204
Dove Gray	TOPQ0211
Sapphire Blue	TOPQ0226
Black	TOPQ0208

## ORDERING REPLACEMENT PARTS

To order replacement parts for the Great Planes ElectroStreak ARF, use the order numbers in the **Replacement Parts List** that follows. Replacement parts are available only as listed. Not all parts are available separately (an aileron cannot be purchased separately, but is only available with the wing kit). Replacement parts are not available from Product Support, but can be purchased from hobby shops or mail order/Internet order firms. Hardware items (screws, nuts, bolts) are also available from these outlets. If you need assistance locating a dealer to purchase parts, visit [www.greatplanes.com](http://www.greatplanes.com) and click on "Where to Buy." If this kit is missing parts, contact **Great Planes Product Support**.

### Replacement Parts List

<u>Order Number</u>	<u>Description</u>	<u>How to Purchase</u>
	Missing pieces.....	Contact Product Support
	Instruction manual.....	Contact Product Support
	Full-size plans .....	Not available
GPMA2261 .....	Wing Set	} Contact Your Hobby Supplier To Purchase These Items
GPMA2260 .....	Fuse Set	
GPMA2262 .....	Tail Set	

### Metric Conversions

1/64" = .4 mm	3/8" = 9.5 mm	12" = 304.8 mm
1/32" = .8 mm	1/2" = 12.7 mm	18" = 457.2 mm
1/16" = 1.6 mm	5/8" = 15.9 mm	21" = 533.4 mm
3/32" = 2.4 mm	3/4" = 19.0 mm	24" = 609.6 mm
1/8" = 3.2 mm	1" = 25.4 mm	30" = 762.0 mm
5/32" = 4.0 mm	2" = 50.8 mm	36" = 914.4 mm
3/16" = 4.8 mm	3" = 76.2 mm	
1/4" = 6.4 mm	6" = 152.4 mm	

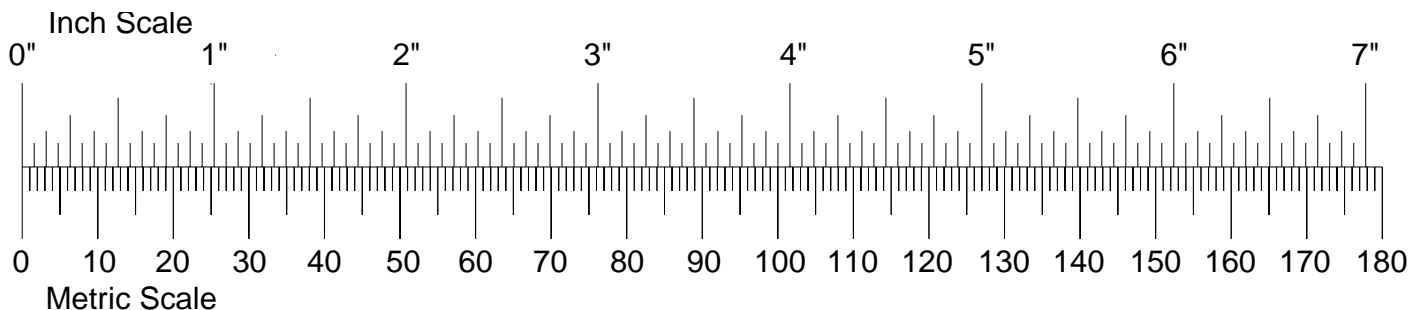

## KIT CONTENTS

Before starting to build, use the **Kit Contents** list to take an inventory of this kit to make sure it is complete, and inspect the parts to make sure they are of acceptable quality. If any parts are missing or are not of acceptable quality, or if you need assistance with assembly, contact **Great Planes Product Support**. When reporting defective or missing parts, use the part names exactly as they are written in the Kit Contents list on this page.

**Great Planes Product Support:**  
**Phone: (217) 398-8970**  
**Fax: (217) 398-7721**  
**E-mail: [airsupport@greatplanes.com](mailto:airsupport@greatplanes.com)**

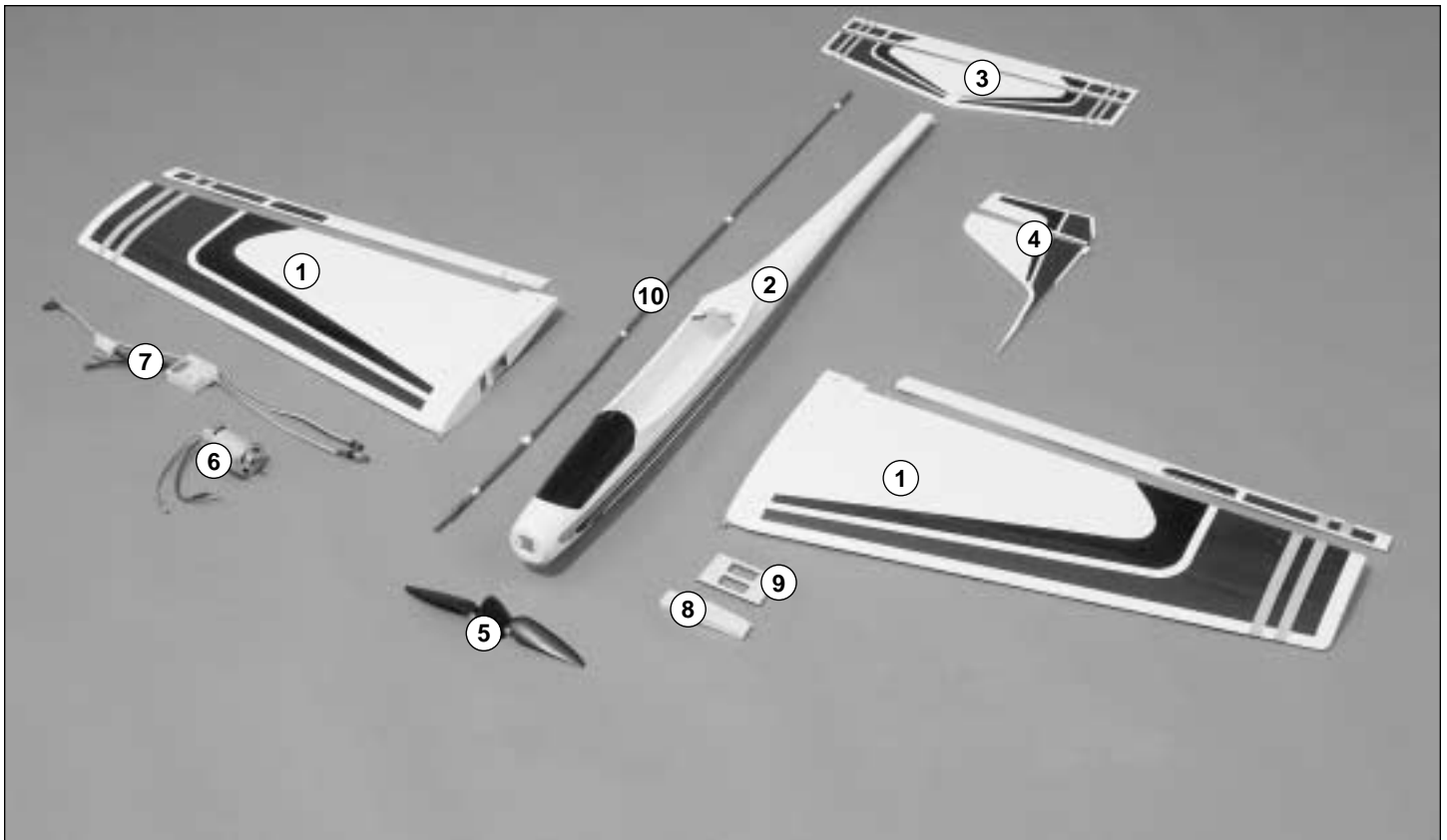

### Kit Contents (Photographed)

- |   |  |
|---|--|
| <ul style="list-style-type: none"> <li>1. R &amp; L Wing Panels w/Ailerons</li> <li>2. Fuselage</li> <li>3. Stab w/Elevator</li> <li>4. Fin w/Rudder</li> <li>5. Folding Propeller w/Spinner</li> <li>6. Motor</li> </ul> | <ul style="list-style-type: none"> <li>7. Electronic Speed Control</li> <li>8. Wing Joiner</li> <li>9. Servo Tray</li> <li>10. Pushrods</li> </ul> |
|---|--|

### Kit Contents (Not Photographed)

- |   |  |   |
|---|--|---|
| <ul style="list-style-type: none"> <li>(1) Battery Tray</li> <li>(1) Aileron Servo Tray</li> <li>(2) Aileron Servo Tray Base</li> <li>(1) Elevator Outer Pushrod Forward Support</li> <li>(2) Hook and Loop Material</li> <li>(2) 1.5mm Set Screw</li> <li>(1) 1.5mm Hex Wrench</li> <li>(2) 1.5mm x 8mm Sheet Metal Screw</li> <li>(2) 1110mm Pull/Pull Cable</li> <li>(2) 2-56 Cable-To-Clevis Connector</li> </ul> | <ul style="list-style-type: none"> <li>(4) 2-56 x 5/8" Machine Screw</li> <li>(2) 6-32 x 3/4" Machine Screw</li> <li>(2) #6 Washer</li> <li>(2) Screw-Lock Pushrod Connector Body</li> <li>(2) 4-40 x 1/4" Socket Head Cap Screw</li> <li>(2) 3mm x 10mm Machine Screw</li> <li>(2) 3mm Washer</li> <li>(12) CA Hinges</li> <li>(5) Nylon Clevis</li> <li>(2) 2mm Torque Rod Horn</li> </ul> | <ul style="list-style-type: none"> <li>(2) Screw-Lock Pushrod Connector Retainer</li> <li>(2) 2-56 x 6" Pushrod Threaded One End</li> <li>(2) Crimp Fitting</li> <li>(1) 6-1/2" White Inner Flex Tube</li> <li>(2) #2 x 3/8" Sheet Metal Screw</li> </ul> |
|---|--|---|

## PREPARATIONS

- ❑ 1. If you have not done so already, remove the major parts of the kit from the box (wing halves, fuselage, tail parts, etc.) and inspect them for damage. If any parts are damaged or missing, contact Product Support at the address or telephone number listed on the front cover.



- ❑ 2. Remove the masking tape and separate the ailerons from the wing, the rudder from the fin and the elevator from the stabilizer. With a covering sock on your covering iron, set the temperature to high and tighten the covering, if necessary. Apply pressure over sheeted areas to **thoroughly** bond the covering to the wood. **Hint:** Poke three or four pin holes in the covering between the “ribs” in the tail surfaces. This will allow the hot air to escape while tightening the covering.

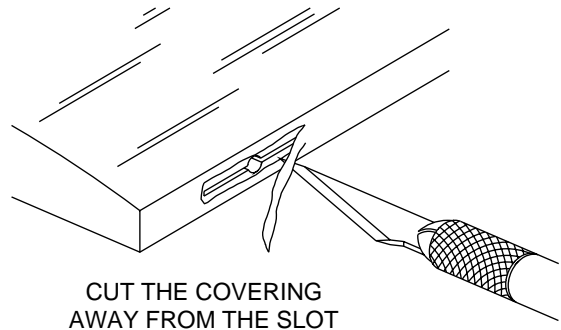

- ❑ 2. Use a sharp #11 blade to cut a strip of covering from the hinge slots in the wing and aileron.

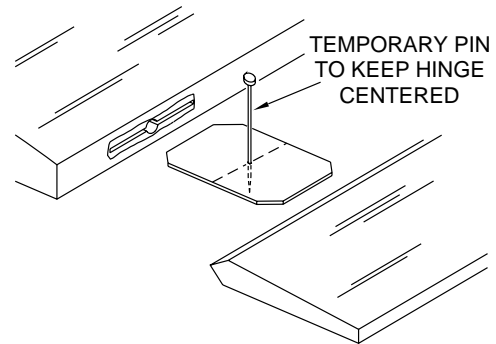

- ❑ 3. Test fit the ailerons to the wing with the hinges. If the hinges don't stay centered, stick a pin through the middle of the hinge to hold it in position.

## BUILD THE WING

### Install the Ailerons

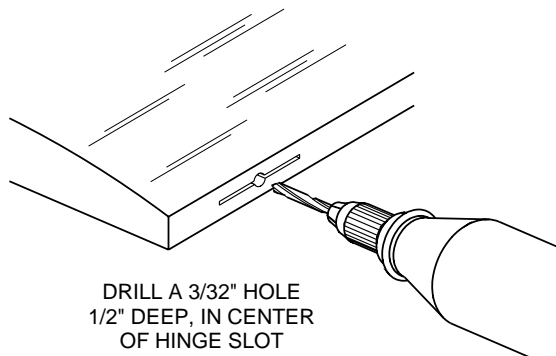

- ❑ 1. Drill a 3/32" [2.3mm] hole, 1/2" [12.7mm] deep in the center of each hinge slot to allow the CA to “wick” in. Follow-up with a #11 blade to clean-out the slots. **Hint:** If you have one, use a high-speed rotary tool to drill the holes.



- ❑ 4. Clean the aileron torque rod with denatured alcohol to remove any contaminants.

- ❑ 5. Mix up a small amount of 6-minute epoxy. Using a toothpick, apply epoxy in the aileron torque rod hole and along the groove in the leading edge of the aileron. Before the epoxy cures, install the aileron on the wing. Remove any pins you may have inserted into the hinges. Adjust the aileron so there is a small gap between the LE of the aileron and the wing. The gap should be small – just enough to see light through or to slip a piece of paper through.



6. Apply six drops of thin CA to the top and bottom of each hinge. Do not use CA accelerator. After the CA and epoxy have fully hardened, test the hinges by pulling on the aileron.

7. Go back to step 1 and repeat the hinge installation for the other aileron.

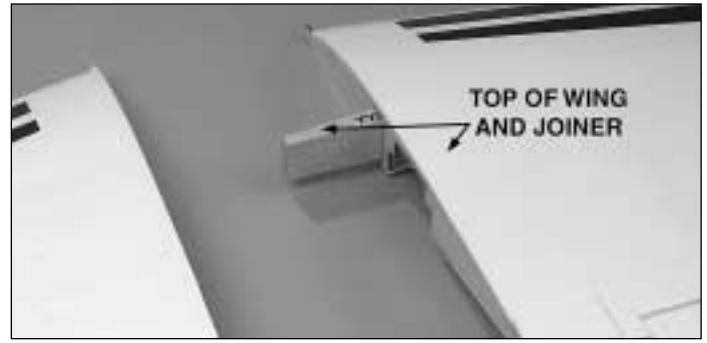

2. Test fit the wing halves together with the wing joiner. Make sure the wing joiner is installed correctly. If it is not, the root of the wings will not fit together correctly. If the wing joiner needs to be sanded so that it will fit in the wing, sand the bottom of the joiner. The top of the wing should be flat when both wing halves are joined.

**Join the Wing**

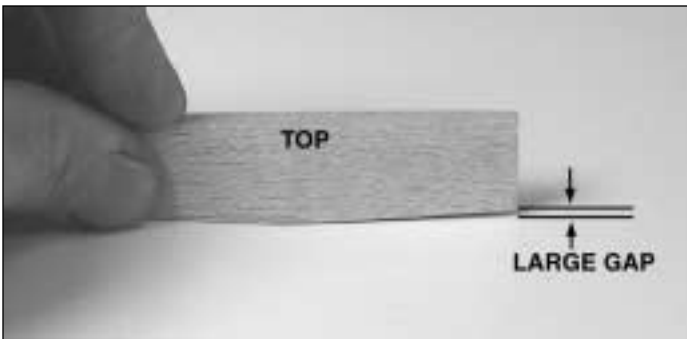
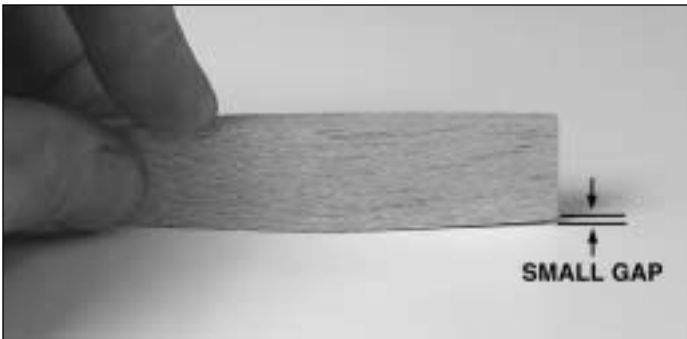

1. The wing joiner has a top and a bottom. To determine which is the top, place the wing joiner on a flat surface and note the gap between the joiner and the flat surface. The side with the smallest gap is the top. Mark top on the wing joiner.



3. Prepare 1/2 oz. of 30-minute epoxy. Working quickly, thoroughly coat the inside of both wing halves where the joiner fits and one half of the joiner with epoxy. Making certain the joiner is upright, insert the coated end into one of the wing halves. Coat the other end of the joiner and the root ribs with the remainder of the epoxy. Join the wing halves tightly, holding them together. Use a paper towel dampened with denatured alcohol to wipe away the excess epoxy that comes out of the wing. Tightly hold the wing together with masking tape, making certain both halves are in full contact and the leading and trailing edges are aligned. Let the wing set until the epoxy has cured.

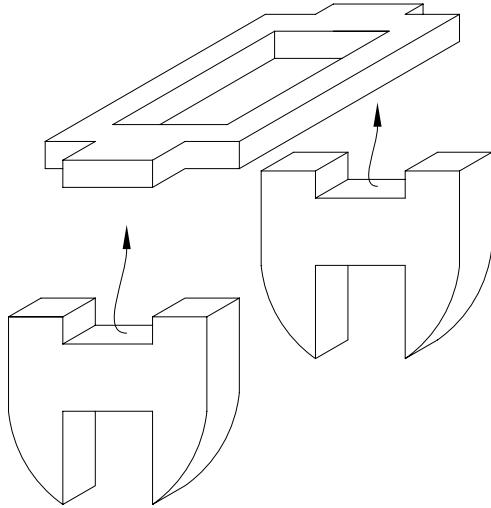

❑ 4. Glue the two aileron servo tray bases and the servo tray in the center of the wing. **Note:** The two bases should straddle the root ribs.

## ASSEMBLE THE FUSELAGE

### Mount the Wing



❑ 1. Inspect the blind nuts that are pressed into the bottom of the wing nut plate inside the fuselage. If the nuts are not securely pressed into the plate, remove them. Apply a dab of 30-minute epoxy to the flange around the blind nuts, then reinsert them into the plate. **Do not** get any epoxy into the threads. Use a 6-32 x 3/4" machine screw and a #6 washer to draw the blind nut all the way up into the wood by tightening the bolt to the top of the plate.

❑ 2. Remove the covering from over the two bolt holes at the trailing edge of the wing.



❑ 3. Test fit the wing to the fuselage and bolt it into position with two 6-32 x 3/4" machine screws and two #6 washers. If necessary, enlarge or adjust the wing bolt holes in the wing so the wing bolts will align with the blind nuts.

### Mount the Stab & Fin

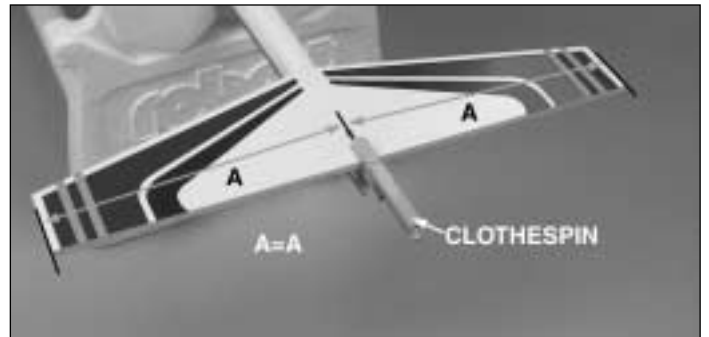

❑ 1. Fit the stab onto the fuselage. Center the trailing edge of the stab on the aft end of the fuselage. A clothespin placed over the stab and fuselage works great for holding the stab in position.



❑ 2. Stick a T-pin into the center of the top of the wing, at the leading edge. Tie a small loop in one end of a 36" [914mm] piece of non-elastic string such as K&S #801 Kevlar thread (K+SR4575). Slip the loop in the string over the T-pin.

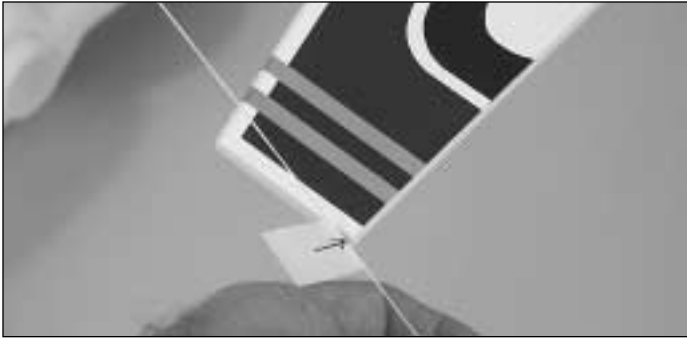

❑ 3. Fold a piece of masking tape over the other end of the string and draw an arrow on it. Slide the tape along the string and align the arrow with one end of the stab. Swing the string over the same position on the other end of the stab. While keeping the trailing edge of the stab centered on the fuselage, adjust the stab and slide the tape along the string until the arrow aligns with both ends of the stab. Be certain the trailing edge of the stab remains centered on the aft end of the fuselage.



❑ 4. Use a fine-point felt-tip pen such as a Top Flite Panel Line Pen (TOPQ2510) to mark the outline of the fuselage onto the bottom of the stab.

❑ 5. Remove the stab from the fuselage. Use a sharp #11 hobby knife or use the **Expert Tip** that follows to cut the covering from the stab along the lines you marked. Use care to cut **only the covering** and **not** into the wood.

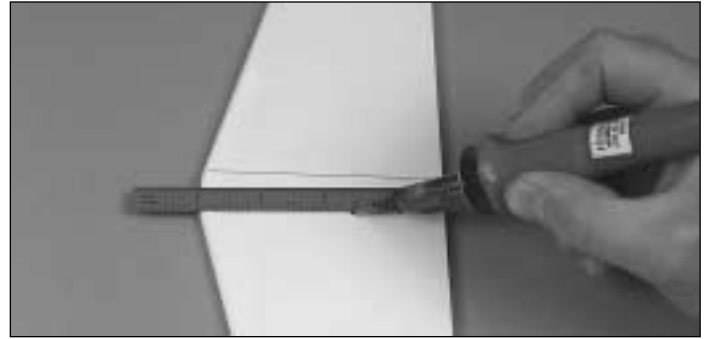

#### ***How to cut covering from balsa***

Use a 25 watt soldering iron to cut the covering from the stab. The tip of the soldering iron doesn't have to be sharp, but a fine tip does work best. Allow the iron to heat fully. Use a metal straightedge to guide the soldering iron at a rate that will just melt the covering and not burn into the wood. The hotter the soldering iron, the faster it must travel to melt a fine cut. Allow the heat to melt the covering. Do not apply a lot of pressure or the wood may be damaged. Peel off the covering.

❑ 6. The same as you did for the wing and aileron, cut the covering from the hinge slots in the stab/elevator and fin/rudder. There are four hinge slots in the stab/elevator and two in the fin/rudder. Drill a 3/32" [2.3mm] hole through the center of each hinge slot.

❑ 7. Lightly sand the top of the stab saddle, on the fuselage, to remove the shine. Clean the surface with rubbing alcohol. This will allow the epoxy to make a secure bond to the fiberglass fuselage.

❑ 8. Using 30-minute epoxy, glue the stab to the fuselage. Apply a light coat of epoxy to the stab saddle and to the bottom of the stab. Position the stab on the fuselage. Make sure the stab is centered on fuselage. Use the string method to align the stab on the fuse. Use clamps or weights to hold the stab against the fuselage. Wipe off the excess epoxy with a paper towel dampened with rubbing alcohol.



❑ 9. With the plane setting in a plane stand, view the plane 5' to 10' from the rear. Check that the stab is parallel to the

wing. If it is not, the following Expert Tip can be used to slightly twist the fuselage.



### ***Straightening a twisted fiberglass fuselage***

Use a heat gun to heat the fuselage between the stab and wing. Try to heat the fuselage evenly. Do not hold the heat gun in one place. It does not require a lot of heat; the fuse needs to be warm. Hold the fuselage in front of the wing and in front of the stab and gently twist. Hold the fuselage in this position until it has cooled. You may need to twist it a few times before you get it in the correct position.



❑ 10. Use a 1/8" drill bit to drill two rudder cable exit holes at the front of the indentations, at the aft end of the fuselage.

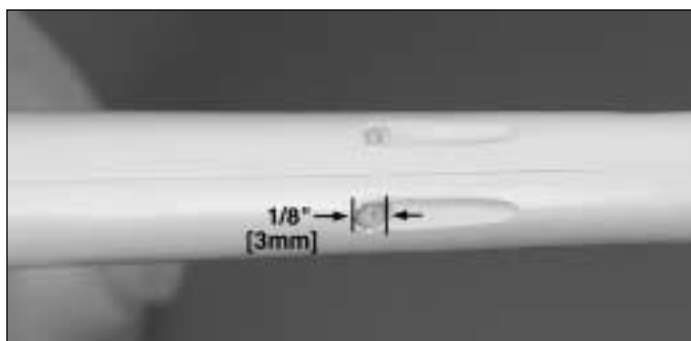

❑ 11. Cut two 1-1/2" [38mm] long cable guide tubes from the 6-1/2" [165mm] white plastic tube. Glue the cable guide tubes in the holes drilled in the previous step. Allow the tubes to extend out of the holes approximately 1/8" [3mm].



❑ 12. Fit the fin into the stab. From the aft end of the plane, sight down the fin, checking that it is aligned with the centerline of the fuselage. Mark the outline of the fin on the stab. Then use the soldering iron technique to remove the covering on the stab. Glue the fin into position using 30-minute epoxy. Use a builder's square to make sure the fin is perpendicular to the stab. Masking tape can be used to hold the fin in position until the epoxy cures.

## ***Install Servo & Battery Tray***

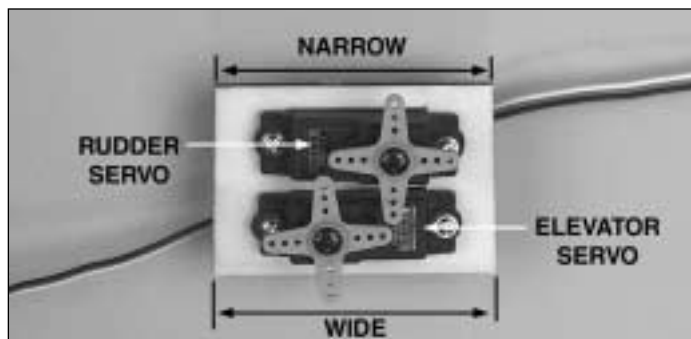

❑ 1. Install the rudder and elevator servos in the servo tray using the hardware that is included with the servos. You may need to trim the servo mounting holes to accommodate the brand of micro servos you are using. Note that the servo tray has a wide side and a narrow side and which direction the servos face compared to the sides.



❑ 2. Position the servo tray in front of the wing nut plate so that the narrow end is towards the aft end of the plane. Make sure that you can get to the servo mounting screws. If there is space between the rudder and elevator servos and the bottom of the fuselage, we recommend that you use a sanding bar to sand a bevel on the sides of the servo tray to allow the tray to set lower. This will leave more room between the elevator and rudder servos and the aileron

torque rods. When satisfied with the fit, use 6-minute epoxy to glue the servo tray to the fuselage sides.

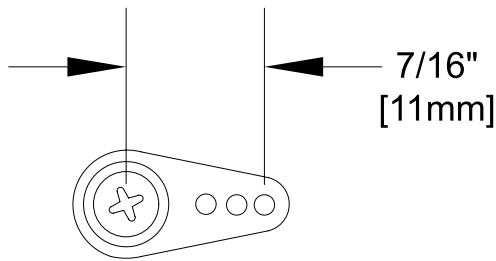

❑ 3. Use a servo arm that has a pushrod mounting hole approximately 7/16" [11mm] out from the center of the arm for the elevator servo. Trim the servo arm so that only one arm remains.

❑ 4. Cut the gray outer pushrod 20" [508mm] long. Sand the outside of the tube with 320-grit sandpaper and wipe it off with a paper towel dampened with rubbing alcohol.



❑ 5. Insert the outer pushrod tube from the aft end of the fuselage. The forward end of the pushrod should be even with the aft edge of the wing saddle. Glue the outer pushrod to the aft brace, pre-installed in the aft end of the fuselage, by holding the fuselage with its nose down and dripping a couple of drops of CA onto the joint between the outer pushrod and aft brace.

❑ 6. Cut the 36" [914mm], threaded on one end pushrod 25" [635mm] long, measured from the threaded end.

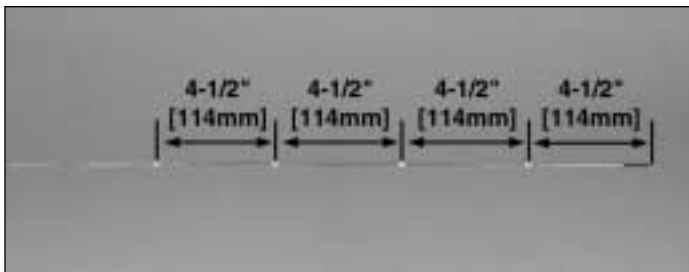

❑ 7. From the remaining white tube, cut four 1/4" [6.3mm] long pushrod guides. Slide the four guides onto the 25" [635mm] pushrod. The first guide should be positioned approximately 4-1/2" [114mm] from the threaded end. Space the remaining three 4-1/2" [114mm] apart. Glue the guides to the pushrod with a drop of thin CA.

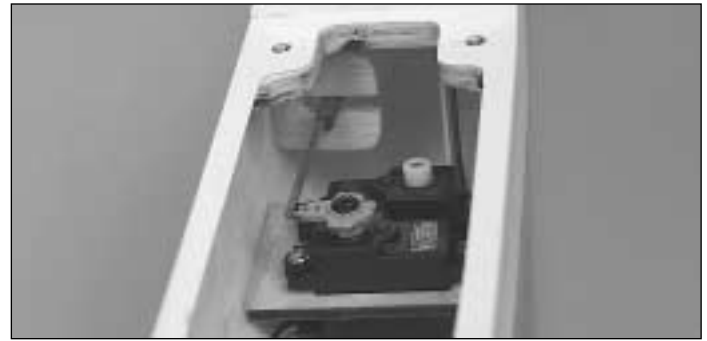

GLUE TO  
FUSELAGE SIDE

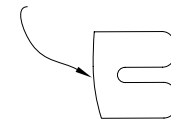

FORWARD PUSHROD  
TUBE BRACE

❑ 8. Insert the non threaded end of the pushrod in the outer pushrod tube. Align the end of the pushrod with the hole in the servo horn, 7/16" from the center of the servo horn. Use 6-minute epoxy to glue the forward pushrod tube brace to the inside of the fuselage, on the right side. The slot in the brace will allow you to adjust the position of the outer pushrod tube so that it is straight before gluing it to the brace.

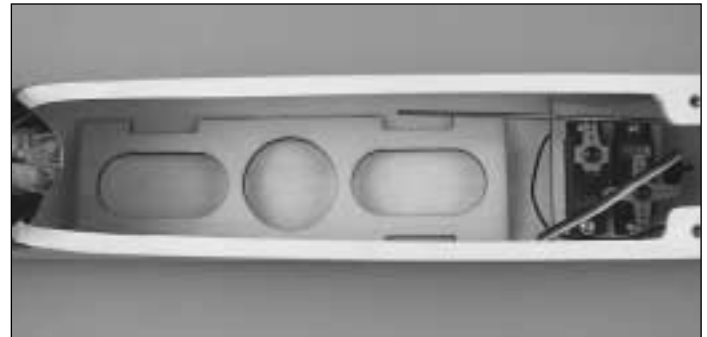

❑ 9. Use 6-minute epoxy to glue the battery tray in the bottom of the fuselage. The tray should be centered between the servo tray and the front of the wing saddle.

### ***Install the Motor & Speed Control***



❑ 1. Insert the motor through the wing opening and align the screw holes in the motor with the holes in the front of the

fuselage. Attach the motor to the fuselage using two 3mm x 10mm machine screws and 3mm washers.

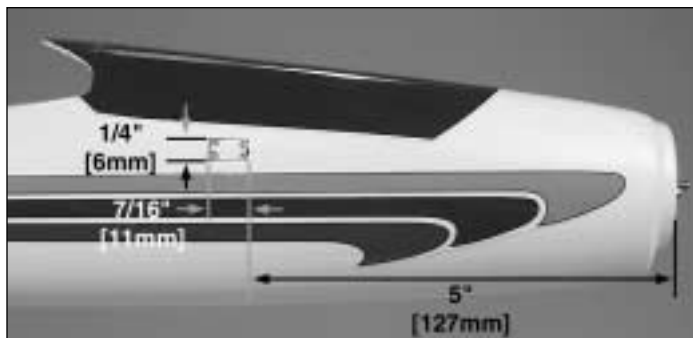

❑ 2. Cut a 7/16" x 1/4" [11mm x 6mm] hole for the speed control on/off switch in the side of the fuselage, approximately 5" [127mm] from the front of the fuselage. We suggest first drawing the rectangle on the side of the fuselage. Then, use a 3/32" [2.3mm] drill bit to drill a hole in each corner of the rectangle.

❑ 3. Use a sharp hobby knife to cut the remainder of the rectangle.



❑ 4. Drill a 1/4" [6mm] hole, 3/4" [19mm] forward of the on/off rectangle. Test fit the motor button in the hole from the outside to check the fit. You may need to enlarge the hole slightly with a hobby knife.



❑ 5. Remove the nut and split washer from the motor button and install the button from the inside. Secure the button to the fuselage with the split washer and nut. Insert the on/off switch, end first, from the inside, through the hole in the fuselage. Carefully pull the switch through the hole, making sure not to damage the wires. Secure the switch to the fuselage with two #2 x 3/8" sheet metal screws.

❑ 6. Plug the electronic speed control into the motor. The red wire from the speed control must plug into the red wire

from the motor and the black into the black. Check that the insulation covers the metal connectors on both plugs. If it does not, use electrical tape to insulate the plugs to prevent them from shorting.

❑ 7. From the hook and loop material, cut a 1-1/2" [38mm] long piece of both material. Clean the back of the electronic speed control with a paper towel dampened with rubbing alcohol. Glue the soft material to the back of the electronic speed control with CA. Glue the rough material to the inside of the fuselage, opposite the on/off switch. Attach the electronic speed control to the side of the fuselage.

### Install the Elevator

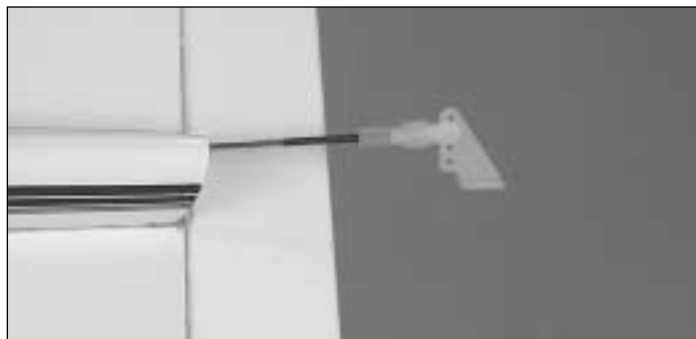

❑ 1. Temporarily attach the elevator to the stab with four CA hinges. Do not glue the hinges. Thread a nylon clevis onto the elevator pushrod, 14 turns, and slide a silicone clevis retainer over the clevis. Attach the clevis in the third hole from the bottom of a small control horn and insert the pushrod in the outer pushrod tube, in the fuselage.

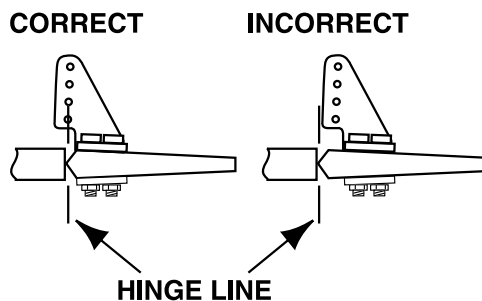
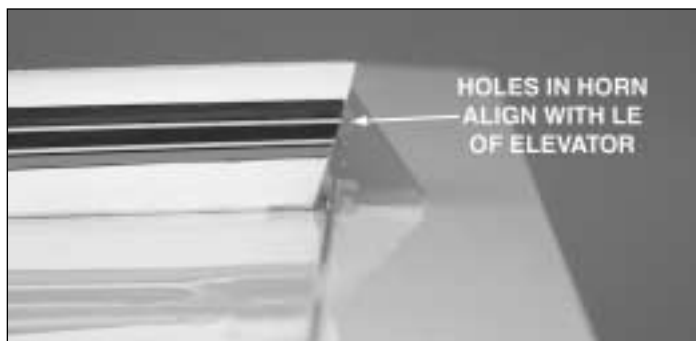

❑ 2. Align the clevis attachment holes with the leading edge of the elevator and center the control horn on the aft end of the fuselage. Mark on the elevator the location of the two control horn mounting holes.

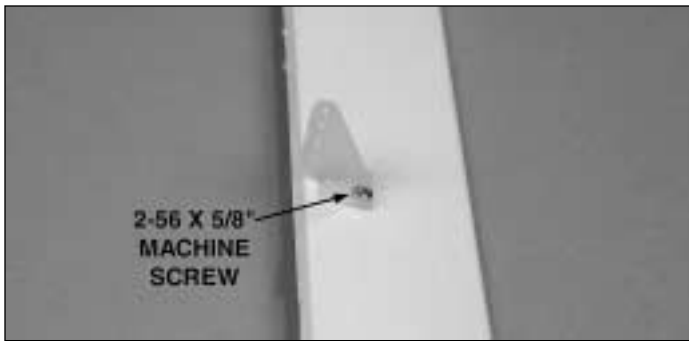

❑ 3. Remove the elevator from the stab. Drill 3/32" holes through the elevator, at the marks. Mount the control horn with two 2-56 x 5/8" machine screws and the nylon mounting plate on the other side of the elevator. Cut off the excess screws.

❑ 4. Re-install the elevator on the stab and glue the hinges with CA. Attach the clevis to the control horn.

❑ 5. Temporarily attach the rudder to the fin. **Do not** glue the hinges. Attach the left side clevis in the second hole from the bottom of a small control horn.

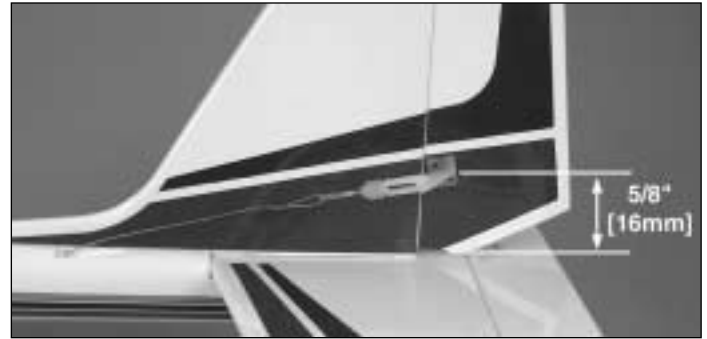

❑ 6. Position the control horn on the rudder so that the horn is approximately 5/8" [16mm] from the bottom of the rudder and the clevis attachment holes are aligned with the leading edge of the rudder. Mark on the rudder, the control horn mounting holes.

❑ 7. Remove the rudder and drill a 3/32" [2.3mm] hole through the rudder at both marks.

### Install the Rudder

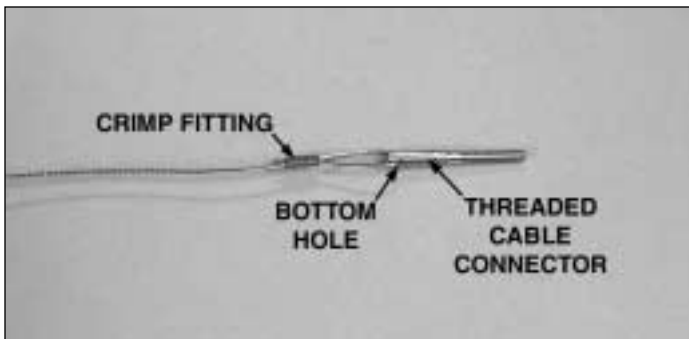

❑ ❑ 1. Slide a crimp fitting on one end of the rudder cable. Insert the cable through the bottom hole in the threaded cable connector and back through the crimp fitting. Crimp the fitting down tightly on the cable.

❑ ❑ 2. Thread a nylon clevis 14 turns onto the threaded cable connector. Install a silicone clevis retainer on the clevis.

❑ 3. Repeat steps one and two to assemble a second rudder cable.

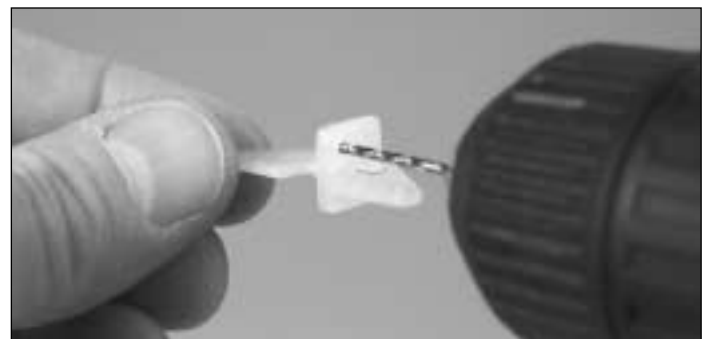

❑ 8. Mark the left rudder control horn with an "L." Remove the control horn from the clevis and tack glue, back-to-back, a second control horn to the left control horn. Drill a 1/16" [1.5mm] hole through both control horn mounting holes in the left control horn.



❑ 4. Insert the two rudder cables in the exits on top of the fuselage.



❑ 9. Attach the left and right control horns to the rudder with two 2-56 x 5/8" machine screws. Trim off the excess screws.

❑ 10. Re-install the rudder on the fin and glue the CA hinges with thin CA.

❑ 11. Attach the clevises in the second hole of each of the control horns.

## RADIO SET-UP

❑ 1. We recommend that the receiver be installed behind the servo tray. This will allow the motor battery to be moved forward and aft to adjust the balance point (C.G.) later. Plug the rudder and elevator servos, and the electronic speed control into the receiver, with a 12" [305mm] servo lead extension and a 12" [305mm] aileron servo lead extension. The receiver can be secured to the bottom of the fuselage with a 1" [25mm] piece of hook and loop material cut from the second strip of material.

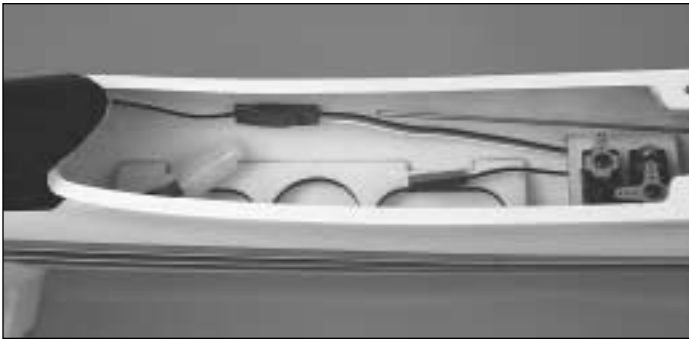

❑ 2. To secure the connection between the electronic speed control lead and the servo extension, wrap a piece of electrical tape or shrink tubing around the plugs. This can then be attached to the inside of the fuselage with CA, keeping it clear of the motor battery.

❑ 3. Plug the motor battery into the electronic speed control. Switch on the transmitter, then the speed control. Center the elevator and rudder servo trim on your transmitter. If needed, remove the rudder and elevator servo arms and center them.



❑ 4. Center the elevator and mark where the elevator pushrod crosses the elevator servo arm. Make a 90° bend at the mark. Cut the pushrod 3/8" [9.5mm] past the bend. Attach the pushrod to the servo arm with a Faslink.

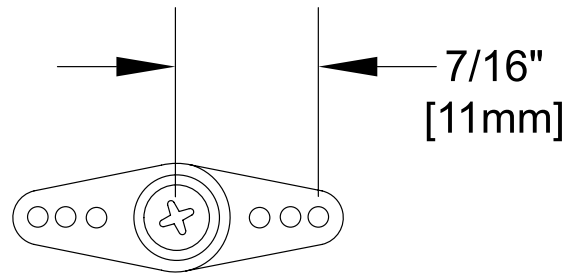

❑ 5. Trim a servo arm so that it has two arms, opposite each other, with the outer holes approximately 7/16" [11mm] from the center.

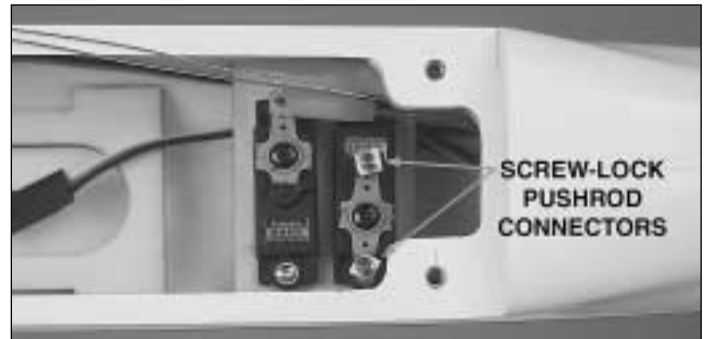

❑ 6. Install a screw-lock pushrod connector in both of the holes 7/16" [11mm] from the center. Use the screw-lock pushrod connector to secure them to the servo arm. Center the servo arm on the rudder servo.

❑ 7. Insert the pull-pull cables through the screw-lock pushrod connectors. Check that the cables are not twisted inside the fuselage.

❑ 8. With the rudder centered, secure the cables in the screw-lock pushrod connectors with 4-40 x 1/4" socket head cap screws. The cables should be tight, but not so tight that they put a strain on the servo. Cut off the excess cable.

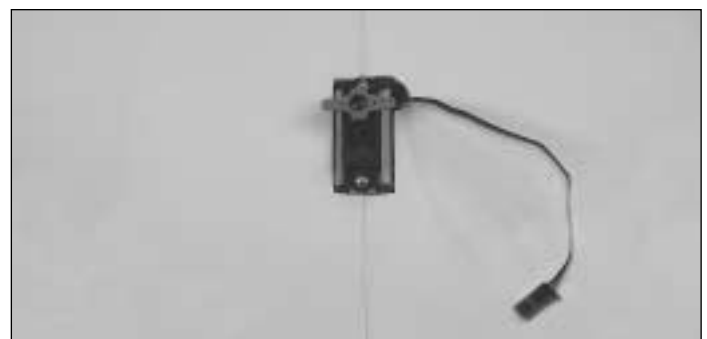

❑ 9. Install the aileron servo in the aileron tray. Install a servo horn with two arms and holes 7/16" [11mm] from the center of the arm.

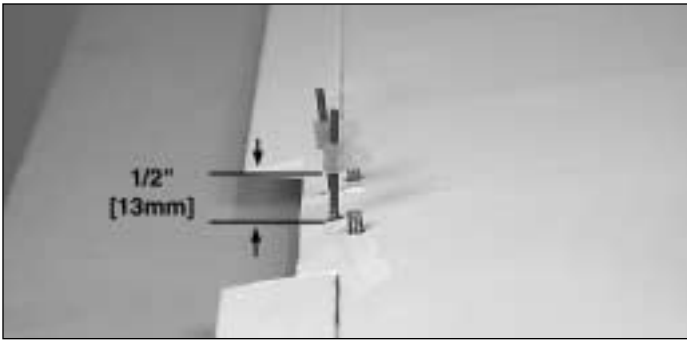

❑ 10. Thread the two nylon torque rod horns onto the aileron torque rods. The bottom of the horn should be approximately 1/2" [13mm] from the wing.

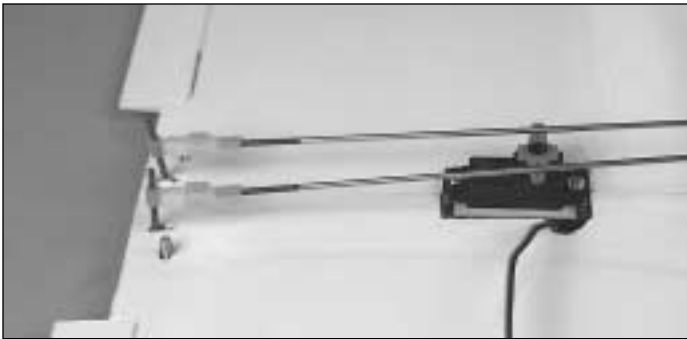

❑ 11. Thread a nylon clevis 14 turns onto the end of the two 2-56 x 6" aileron pushrods. Slide a silicone retainer over both clevises. Attach the clevises to the torque rod horns.

❑ 12. With the aileron servo and ailerons centered, mark the aileron pushrods where they cross the aileron servo arm. Make a 90° bend at the marks and cut the pushrod 3/8" [9.5mm] past the bend. Attach the pushrods to the aileron servo arm with nylon Faslinks. Cut off the excess threads on the aileron torque rods.

## ASSEMBLE & INSTALL THE FOLDING PROPELLER



❑ 1. Note that the aluminum propeller hub has two holes that are recessed. These holes are to the back of the spinner.



❑ 2. Attach the propeller blades to the hub with two 5/64" x 3/8" [1.9mm x 9.5mm] pins. Check that the blades move freely. If they do not, lightly sand the root of each blade until they do.

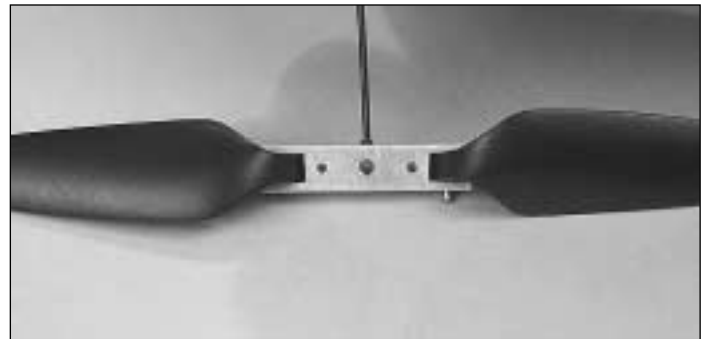

❑ 3. Thread the two 1.5mm set screws into the aluminum hub.

❑ 4. Insert the aluminum hub in the back of the spinner. Secure the spinner to the hub with two 1.5mm x 8mm sheet metal screws.

❑ 5. Attach the spinner to the motor shaft. One of the set screws must tighten down on the flat of the motor shaft. If it does not, the prop may come off of the motor shaft. Check that both set screws are tight.

## Battery Installation

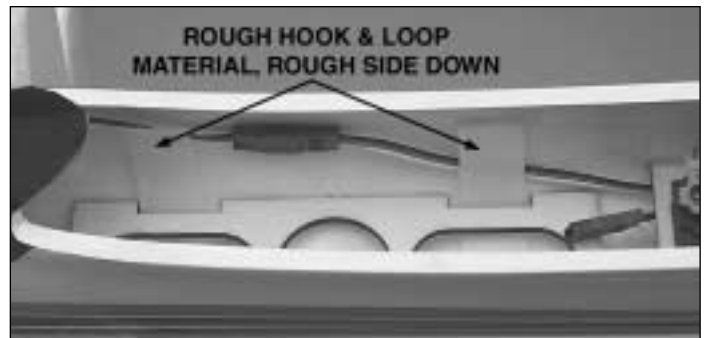

❑ 1. Insert the rough hook-and-loop material, rough side down, under the battery tray.



- ❑ 2. Position the motor battery on the tray. Attach the soft hook-and-loop material to the rough material to secure the battery in place.

## GET THE MODEL READY TO FLY

### Check the Control Directions

- ❑ 1. Switch on the transmitter, connect the motor battery to the electronic speed control and switch on the speed control.
- ❑ 2. With the transmitter and receiver on, check all the control surfaces to see if they are centered. If necessary, adjust the clevises on the pushrods to center the control surfaces.

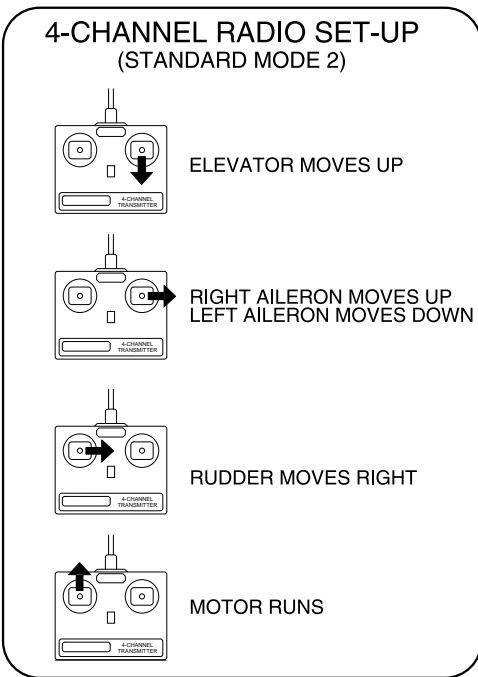

- ❑ 3. Make certain that the control surfaces respond in the correct direction as shown in the diagram. If any of the controls respond in the wrong direction, use the servo reversing in the transmitter to reverse the servos connected to those controls. Be certain the control surfaces have remained centered. Adjust if necessary.

### Set the Control Throws

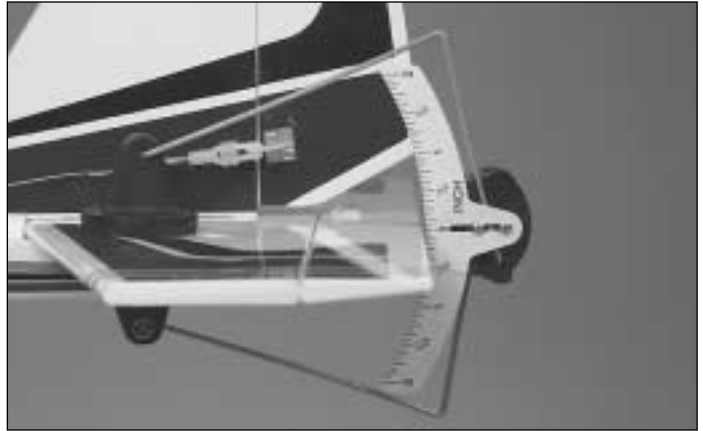

Use a Great Planes AccuThrow (or a ruler) to accurately measure and set the control throw of each control surface as indicated in the chart that follows. If your radio does not have dual rates, we recommend setting the throws at the low rate setting.

**Note:** The throws are measured at the **widest part** of the elevators, rudder and ailerons.

**These are the recommended control surface throws:**

	High Rate	Low Rate
<b>ELEVATOR:</b>	1/2" [13mm] up 3/8" [9.5mm] down	3/8" [9.5mm] up 5/16" [8mm] down
<b>RUDDER:</b>	1-1/4" [32mm] right 1-1/4" [32mm] left	1" [25mm] right 1" [25mm] left
<b>AILERONS:</b>	3/16" [5mm] up 3/16" [5mm] down	1/8" [3mm] up 1/8" [3mm] down

**IMPORTANT:** The ElectroStreak ARF has been **extensively** flown and tested to arrive at the throws at which it flies best. Flying your model at these throws will provide you with the greatest chance for successful first flights. If, after you have become accustomed to the way the ElectroStreak ARF flies, and you would like to change the throws to suit your taste, this is fine. However, too much control throw could make the model difficult to control, so remember, "More is not always better."

## Balance the Model (C.G.)

More than any other factor, the **C.G.** (balance point) can have the **greatest** effect on how a model flies, and may determine whether or not your first flight will be successful. If you value this model and wish to enjoy it for many flights, **DO NOT OVERLOOK THIS IMPORTANT PROCEDURE.** A model that is not properly balanced will be unstable and possibly unflyable.

At this stage the model should be in ready-to-fly condition with all of the systems in place including the motor, prop, electronic speed control, motor battery and the radio system.

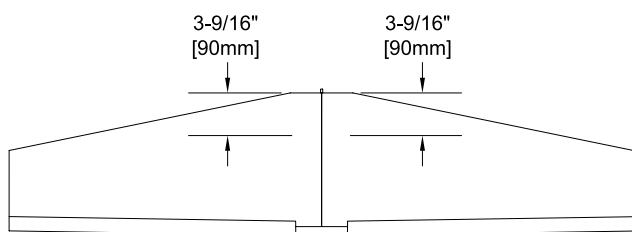

1. Use a felt-tip pen or 1/8"-wide tape to accurately mark the C.G. on the bottom of the wing on both sides of the fuselage. The C.G. is located 3-9/16" [90mm] back from the leading edge of the wing.

This is where your model should balance for your first flights. Later, you may wish to experiment by shifting the C.G. up to 3/16" [5mm] forward or 3/16" [5mm] back to change the flying characteristics. Moving the C.G. forward may improve the smoothness and stability, but it may then require more speed for hand launch and make it more difficult to slow for landing. Moving the C.G. aft makes the model more maneuverable, but could also cause it to become too difficult for you to control. In any case, start at the location we recommend and do not at any time balance your model outside the recommended range.

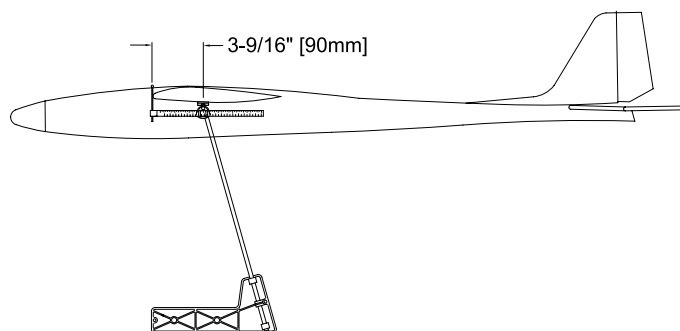

2. With the wing attached to the fuselage, and all parts of the model installed (ready to fly), place the model right side

up on a Great Planes CG Machine, or lift it right side up at the balance point you marked.

3. When the ElectroStreak ARF is properly balanced, the stab will be level. If the tail drops, the model is "tail heavy" and the motor battery must be shifted forward or weight must be added to the nose to balance. If the nose drops, the model is "nose heavy" and the motor battery must be shifted aft or weight must be added to the tail to balance. If possible, relocate the motor battery to minimize or eliminate any additional weight required. If additional weight is required, use Great Planes (GPMQ4485) "stick-on" lead. A good place to add stick-on nose weight is inside the front of the fuselage. Begin by placing incrementally increasing amounts of weight in the fuse until the model balances. Once you have determined the amount of weight required, it can be permanently attached. If required, tail weight may be added to the inside of the aft end of the fuselage. Make sure the tail weight does not interfere with the movement of the elevator pushrod.

If moving the motor battery forward or aft will balance the plane without adding additional weight, mark the battery tray or the fuselage inside where the aft end of the battery should be placed. This will allow you to position the battery correctly before each flight.

4. **IMPORTANT:** If you found it necessary to add any weight, recheck the C.G. after the weight has been installed.

## Balance the Model Laterally

1. With the wing level, have an assistant help you lift the model by the motor shaft and the bottom of the fuse under the TE of the fin. Do this several times.
2. If one wing always drops when you lift the model, it means that side is heavy. Balance the airplane by adding weight to the other wing tip. **An airplane that has been laterally balanced will track better in loops and other maneuvers.**

## PREFLIGHT

## Identify Your Model

No matter if you fly at an AMA sanctioned R/C club site or if you fly somewhere on your own, you should always have your name, address, telephone number and AMA number on or inside your model. It is **required** at all AMA R/C club flying sites and AMA sanctioned flying events. Fill out the identification tag on page 21 and place it on or inside your model.

## Charge the Batteries

Follow the battery charging instructions that came with your radio control system to charge the transmitter. You should always charge your transmitter batteries the night before you go flying, and at other times as recommended by the radio manufacturer.

## PROPER CARE OF YOUR MOTOR

1. The included motor will benefit from a short “break-in” by running the motor without the propeller for at least 15 minutes. This will seat the motor brushes on the commutator, insuring that the motor will provide full power for your first flight and extend the life of your motor. If you notice a decrease in motor power after several flights, it may be due to carbon build-up on the brushes or commutator. To remove this build-up, repeat the above break-in procedure.
2. The bronze bushings in the motors are self-lubricating, but their life may be extended by applying a very small amount of light machine oil to the point where the motor shaft contacts the bushings after every hour or two of run time. **Note:** A drop of oil is far too much. You should apply the oil with a toothpick. **Never oil the inside of the motor.**
3. Using multiple battery packs to run the motor for successive flights may cause the motor to become excessively hot. We recommend at least a 10-minute cool-down period between flights.
4. The ideal power source for the ElectroStreak ARF is a 7-cell, 8.4 volt 1700 – 3000 mAh battery pack. The use of a higher voltage battery may reduce the motor life and damage the electronic speed control.

## PERFORMANCE TIPS

1. A new battery pack should be “cycled” for best results. You should peak charge the battery, then discharge it almost completely by actually running your motor with the propeller attached. Do this 2 or 3 times on the ground before actually flying. Be sure you remove the battery from the airplane between each cycle and allow it and the motor to cool before recharging.
2. The standard Tamiya battery connectors supplied with your electronic speed control and motor battery are adequate for most installations. However, if you are looking for maximum performance, you may want to consider installing high-performance battery connectors such as DuraTrax® Powerpole™ connectors (DTXC2300).
3. Examine your propeller for irregularities caused by the injection molding process. Carefully remove the imperfections with fine sandpaper.

## Ground Check

After you break-in the motor on the model, inspect the model closely to make sure all screws remained tight, the hinges are secure, the prop is secure and all pushrods and connectors are secure.

## Range Check

Whenever you go to the flying field, check the operational range of the radio before the first flight of the day. First, make sure no one else is on your frequency (channel). Have an assistant hold the model, staying clear of the prop. With your transmitter on, you should be able to walk at least 100 feet away from the model and still have control. While you work the controls, have your assistant tell you what the control surfaces are doing. Repeat this test with the motor running at various speeds. If the control surfaces are not always responding correctly, do not fly! Find and correct the problem first. Look for loose servo connections or corrosion, loose bolts that may cause vibration, a defective on/off switch, low battery voltage, a damaged receiver antenna, or a receiver crystal that may have been damaged from a previous crash. If the radio appears to only be affected when the motor is running, try moving your receiver and receiver antenna farther away from the motor battery and motor. Also, installing a couple more capacitors on the motor may help. The capacitors should be soldered from the terminals to the motor case, and from one terminal to the other.

## AMA SAFETY CODE (excerpt)

Read and abide by the following Academy of Model Aeronautics Official Safety Code:

### GENERAL

1. I will not fly my model aircraft in sanctioned events, air shows, or model flying demonstrations until it has been proven to be airworthy by having been previously successfully flight tested.
2. I will not fly my model aircraft higher than approximately 400 feet within 3 miles of an airport without notifying the airport operator. I will give right of way to, and avoid flying in the proximity of full-scale aircraft. Where necessary an observer shall be used to supervise flying to avoid having models fly in the proximity of full-scale aircraft.
3. Where established, I will abide by the safety rules for the flying site I use, and I will not willfully and deliberately fly my models in a careless, reckless and/or dangerous manner.
7. I will not fly my model unless it is identified with my name and address or AMA number, on or in the model.

9. I will not operate models with pyrotechnics (any device that explodes, burns, or propels a projectile of any kind).

### RADIO CONTROL

1. I will have completed a successful radio equipment ground check before the first flight of a new or repaired model.

2. I will not fly my model aircraft in the presence of spectators until I become a qualified flier, unless assisted by an experienced helper.

3. I will perform my initial turn after takeoff away from the pit or spectator areas, and I will not thereafter fly over pit or spectator areas, unless beyond my control.

4. I will operate my model using only radio control frequencies currently allowed by the Federal Communications Commission.

## CHECK LIST

During the last few moments of preparation your mind may be elsewhere anticipating the excitement of the first flight. Because of this, you may be more likely to overlook certain checks and procedures that should be performed before the model is flown. To help avoid this, a check list is provided to make sure these important areas are not overlooked. Many are covered in the instruction manual, so where appropriate, refer to the manual for complete instructions. Be sure to check the items off as they are completed (that's why it's called a *check list!*).

- 1. Check the C.G. according to the measurements provided in the manual.
- 2. Be certain the motor battery and receiver are securely mounted in the fuse.
- 3. Extend your receiver antenna and make sure it has a strain relief inside the fuselage to keep tension off the solder joint inside the receiver.
- 4. Balance your model *laterally* as explained in the instructions.
- 5. Use threadlocking compound to secure critical fasteners such as the cap screws that hold the rudder cable in the screw-lock pushrod connectors.
- 6. Make sure all hinges are **securely** glued in place.
- 7. Reinforce holes for wood screws with thin CA where appropriate (servo mounting screws).
- 8. Confirm that all controls operate in the correct direction and the throws are set up according to the manual.
- 9. Make sure there are silicone retainers on all the clevises and that all servo arms are secured to the servos with the screws included with your radio.
- 10. Secure connections between servo wires and Y-connectors or servo extensions, and the connection between your battery pack and the on/off switch with vinyl tape, heat shrink tubing or special clips suitable for that purpose.

- 11. Use an incidence meter to check the wing for twists and attempt to correct before flying.
- 12. Tighten the set screws in the propeller hub.
- 13. Place your name, address, AMA number and telephone number on or inside your model.
- 14. If you wish to photograph your model, do so before your first flight.
- 15. Remember to range check your radio when you get to the flying field.

## FLYING

The ElectroStreak ARF is a great-flying model that flies smoothly and predictably. The ElectroStreak ARF does not, however, possess the self-recovery characteristics of a primary R/C trainer and should be flown only by experienced R/C pilots.

**CAUTION (THIS APPLIES TO ALL R/C AIRPLANES):** If, while flying, you notice any unusual sounds, such as a low-pitched "buzz," this may indicate control surface *flutter*. Because flutter can quickly destroy components of your airplane, any time you detect flutter you must **immediately** cut the throttle and land the airplane! Check all servo grommets for deterioration (this may indicate which surface fluttered), and make sure all pushrod linkages are secure and free of play. If the control surface fluttered once, it probably will flutter again under similar circumstances unless you can eliminate the free-play or flexing in the linkages. Here are some things which can cause flutter: Excessive hinge gap; Not mounting control horns solidly; Poor fit of clevis pin in horn; Side-play of pushrod in guide tube caused by tight bends; Excessive *play* or *backlash* in servo gears; and Insecure servo mounting.

## Takeoff

Switch on the transmitter and make sure the throttle stick is back (pulled towards you). Switch on the electronic speed control. If you have dual rates on your transmitter, set them to low. For the first flight have an assistant hand launch the plane for you. This will allow you to have both hands on the transmitter in case the plane is out of trim. To launch the ElectroStreak ARF, grip the fuselage under the wing, keeping all body parts away from the propeller. Press the motor button and move the throttle stick to full power. Toss the plane level **into the wind**. Allow the ElectroStreak ARF to gain speed and climb out at a shallow angle before turning.

## Flight

Take it easy with the ElectroStreak ARF for the first few flights, gradually getting acquainted with it as you gain

confidence. Adjust the trims to maintain straight and level flight. After flying around for a few minutes, and while still at a safe altitude with plenty of battery power remaining, practice slow flight and execute practice landing approaches by reducing the throttle to see how the model handles at slower speeds. Add power to see how she climbs as well. Continue to fly around, executing various maneuvers and making mental notes (or having your assistant write them down) of what trim or C.G. changes may be required to fine tune the model so it flies the way you like. Mind your battery power, but use this first flight to become familiar with your model before landing.

## Landing

With electric planes it's best to land with some battery power remaining. This will allow you to abort the landing and go around again if needed. To initiate a landing approach, lower the throttle while on the downwind leg. Allow the nose of the model to pitch downward to gradually bleed off altitude. Continue to lose altitude, but maintain airspeed by keeping the nose down as you turn onto the crosswind leg. Make your final turn toward the runway (into the wind) keeping the nose down to maintain airspeed and control. Level the attitude when the model reaches the landing area, modulating the throttle as necessary to maintain your glide path and airspeed. If you are going to overshoot, smoothly advance the throttle (always ready on the right rudder to counteract torque) and climb out to make another attempt. When you're ready to make your landing flare and the model is a foot or so off the ground, smoothly increase up elevator until it gently touches down.

One final note about flying your model. Have a goal or flight plan in mind for **every** flight. This can be learning a new maneuver(s), improving a maneuver(s) you already know, or learning how the model behaves in certain conditions (such as on high or low rates). This is not necessarily to improve your skills (*though it is never a bad idea!*), but more importantly so you do not surprise yourself by impulsively attempting a maneuver and suddenly finding that you've run out of time, altitude or airspeed. Every maneuver should be deliberate, not impulsive. For example, if you're going to do a loop, check your altitude, mind the wind direction (anticipating rudder corrections that will be required to maintain heading), remember to throttle back at the top, and make certain you are on the desired rates (high/low rates). A flight plan greatly reduces the chances of crashing your model just because of poor planning and impulsive moves. **Remember to think.**

**Have a ball! But always stay in control and fly in a safe manner.**

**GOOD LUCK AND GREAT FLYING!**

**Make a copy of this identification tag, fill it out and affix it to your model.**

This model belongs to:
_____
Name
_____
Address
_____
City, State Zip
_____
Phone number
_____
AMA number

## OTHER ITEMS AVAILABLE FROM GREAT PLANES



### Great Planes Spectra™ ARF

The all-wood, preassembled, 2-meter Spectra ARF arrives expertly covered with Top Flite® MonoKote® film. An included Goldfire 550 motor and 8 x 4 folding prop quickly carry it to soaring altitudes following an easy hand-launch. The wing features a triple taper planform and semi-symmetrical airfoil that increases stability for smooth, forgiving flight. Required are a 3-channel radio, NiCd battery and charger. **GPMA1050**



### Great Planes ElectriCub™

Great Planes combines the looks of one of aviation's most popular aircraft with quiet, powerful electric performance! This 58.75" span kit features precisely interlocking wood parts for easy assembly. Also included are bolt-on wings; a

mount for either direct- or gear-drive motors; precision-formed windows; and a flat-bottom wing with ailerons and less dihedral for stronger aerobatics. Requires a 4-channel radio w/4 mini servos (or 3 mini servos and speed control), Speed 600 motor, 7-cell, 8.4V NiCd battery, charger and 2+ rolls of MonoKote. **GPMA0156**



**Great Planes ElectriFly™ Sanyo 1900SCR Thrust 7-Cell Battery**

The perfect pack for high-performance electric flight – and very affordable! These batteries are assembled from powerful, low-resistance Sanyo N-1900SCR cells, and feature flexible, 14-gauge wire to handle high-current applications. Side-by-side cell assembly enables the packs to fit easily inside narrow fuselages. **GPMP0741**



**DuraTrax® IntelliPeak™ AC/DC Pulse Charger**

The DuraTrax IntelliPeak AC/DC Charger offers an affordable middle ground between features-stingy sport chargers and high-cost battery management systems. This microprocessor-controlled unit handles NiCds as well as NiMH packs, and includes pulsed peak charging; 1-button set up; adjustable fast-charge current; 100mA trickle charge; single and continuous settings for discharge/cycling; and lead with standard connector. 1-year warranty. **DTXP4100**



**Futaba® 4VF 4-Channel Radio**

The 4VF fits every 4-channel flier's hand—and needs—like a glove. An ergonomically designed case offers fatigue-free flying. Gimbal sticks adjust to your touch, mechanical trims are in easy reach from the sticks and servo reversing switches are positioned to prevent accidental changes. There's also a built-in trainer system, compatible with all Futaba FM systems, plus full NiCds and a charger for modeler convenience. The 4VF includes an R127DF receiver and three S3003 standard servos. 72 MHz. **FUTJ61\*\***



**Futaba S3101 Micro Precision Servos**

Minimize on-board weight with these compact but powerful servos, featuring nylon gears, oilite bushing, and preinstalled "X" servo horn (round horn also included). Speed: 0.18 sec @ 60 degrees. Torque: 34.7 oz-in. Length: 1.10 in. Width: 0.51 in. Height: 1.17 in. Weight: 0.6 oz. Connector: "J" type with approx. 5" wire. One-year warranty. **FUTM0033**

