

# Shoestring

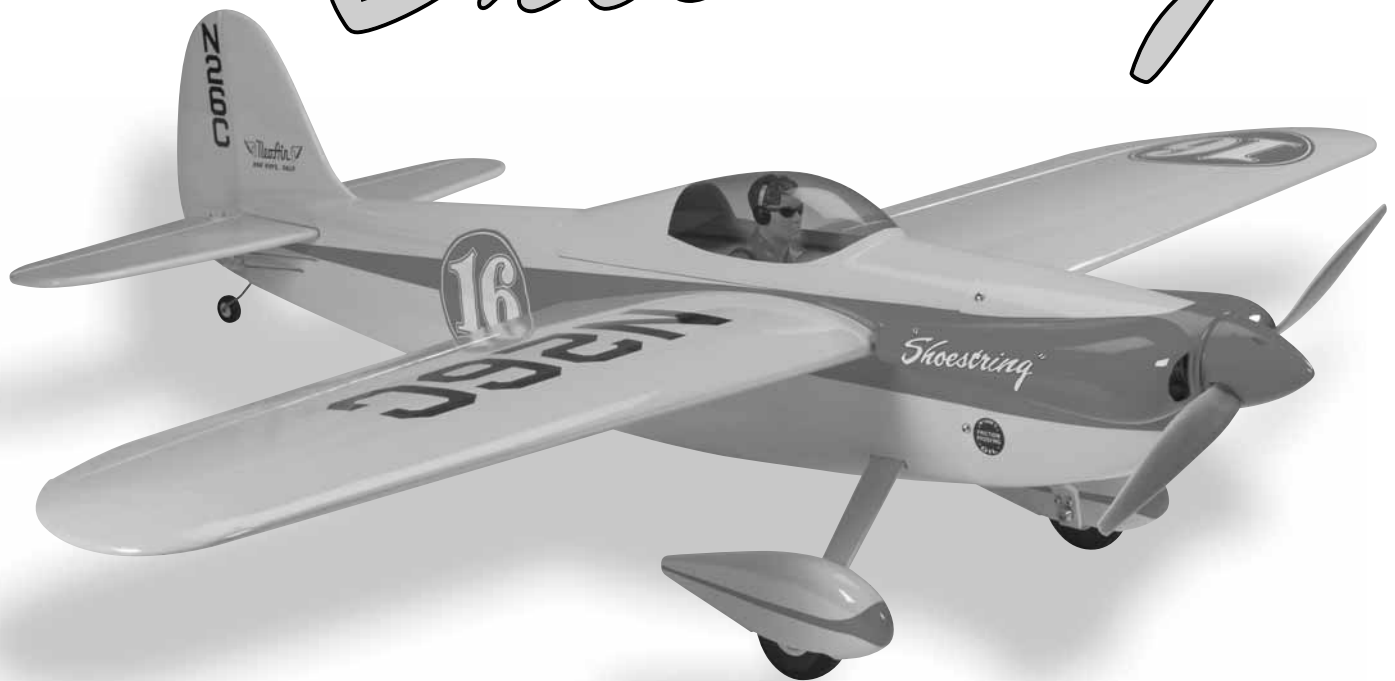

## INSTRUCTION MANUAL

### SPECIFICATIONS

<b>Wingspan:</b>	54 in [1370mm]	<b>Weight:</b>	6.5–7 lb [2950–3170 g]	<b>Radio:</b>	4-channel minimum with 4–5 servos and standard receiver
<b>Wing Area:</b>	572 in <sup>2</sup> [36.9 dm <sup>2</sup> ]	<b>Wing Loading:</b>	26–28 oz/ft <sup>2</sup> [79–85 g/dm <sup>2</sup> ]	<b>Engine:</b>	.46-.55 cu in [7.5–9cc] two-stroke, .70-.81 cu in [11.5–13.5cc] four-stroke, RimFire™ .46 (42-60-800) brushless outrunner motor

### WARRANTY

Great Planes® Model Manufacturing Co. guarantees this kit to be free from defects in both material and workmanship at the date of purchase. This warranty does not cover any component parts damaged by use or modification. **In no case shall Great Planes' liability exceed the original cost of the purchased kit.** Further, Great Planes reserves the right to change or modify this warranty without notice.

In that Great Planes has no control over the final assembly or material used for final assembly, no liability shall be assumed nor accepted for any damage resulting from the use by the user of the final user-assembled product. By the act of using the user-assembled product, the user accepts all resulting liability.

**If the buyer is not prepared to accept the liability associated with the use of this product, the buyer is advised to return**

**this kit immediately in new and unused condition to the place of purchase.**

To make a warranty claim, send the defective part or item to Hobby Services at the address below:

**Hobby Services**  
3002 N. Apollo Dr. Suite 1  
Champaign IL 61822 USA

Include a letter stating your name, return shipping address, as much contact information as possible (daytime telephone number, fax number, e-mail address), a detailed description of the problem and a photocopy of the purchase receipt. Upon receipt of the package the problem will be evaluated as quickly as possible.

READ THROUGH THIS MANUAL BEFORE STARTING CONSTRUCTION. IT CONTAINS IMPORTANT INSTRUCTIONS AND WARNINGS CONCERNING THE ASSEMBLY AND USE OF THIS MODEL.



Champaign, Illinois  
(217) 398-8970, Ext 5  
airsupport@greatplanes.com

## TABLE OF CONTENTS

INTRODUCTION .....	2
SAFETY PRECAUTIONS .....	3
DECISIONS YOU MUST MAKE .....	3
Radio Equipment .....	3
Power System Recommendations .....	3
Propeller.....	4
Batteries and Charger.....	4
ADDITIONAL ITEMS REQUIRED .....	4
Required Hardware and Accessories .....	4
Adhesives and Building Supplies .....	4
Optional Supplies and Tools.....	4
Building Stand.....	5
IMPORTANT BUILDING NOTES .....	5
ORDERING REPLACEMENT PARTS .....	5
KIT INSPECTION .....	6
PREPARATIONS .....	7
ASSEMBLE THE WINGS .....	7
ASSEMBLE THE TAIL SECTION .....	9
INSTALL THE TAIL SERVOS AND PUSHRODS .....	12
ASSEMBLE & INSTALL THE MAIN LANDING GEAR ..	13
INSTALL THE POWER SYSTEM .....	15
Glow Engine Installation .....	15
Brushless Motor Installation.....	18
FINISH THE MODEL .....	21
APPLY THE DECALS .....	23
GET THE MODEL READY TO FLY .....	23
Install and Operate the Motor Battery .....	23
Check the Control Directions .....	24
Set the Control Throws .....	25
Balance the Model (C.G.).....	25
Balance the Model Laterally.....	26
PREFLIGHT .....	26
Identify Your Model.....	26
Charge the Batteries.....	26
Balance Propellers.....	26
Ground Check.....	26
Range Check .....	26
ENGINE SAFETY PRECAUTIONS.....	27
LITHIUM BATTERY HANDLING AND USAGE .....	27
AMA SAFETY CODE.....	27
CHECK LIST .....	28
FLYING.....	28
Fuel Mixture Adjustments .....	29
Takeoff .....	29
Flight .....	29
Landing .....	29

## INTRODUCTION



Congratulations on your purchase of the Great Planes Shoestrung .46 ARF! This beautiful, fiberglass fuselage model follows on the success of Great Planes' larger, .60-sized version. Much of the typical ARF building work has been completed at the factory, leaving only the final steps needed to get you airborne quickly. Even a pilot comes already installed!

You'll enjoy sport performance with a .46-size engine, or experience scale-like speeds that recall the Cleveland Air Races with a .55. Accommodations have also been made for installing a brushless power system. A magnetic canopy hatch makes radio access and battery changes a breeze! The two-piece wing with a lightweight, carbon wing tube allows for easy transport.

For the latest technical updates or manual corrections to the Shoestrung .46 ARF visit the Great Planes web site at [www.greatplanes.com](http://www.greatplanes.com). Open the "Airplanes" link, then select the Shoestrung .46 ARF. If there is new technical information or changes to this model a "tech notice" box will appear in the upper left corner of the page.

## AMA

If you are not already a member of the AMA, please join! The AMA is the governing body of model aviation and membership provides liability insurance coverage, protects modelers' rights and interests and is required to fly at most R/C sites.



### Academy of Model Aeronautics

5151 East Memorial Drive

Muncie, IN 47302

Tele: (800) 435-9262

Fax (765) 741-0057

Or via the Internet at:

<http://www.modelaircraft.org>

**IMPORTANT!!!** Two of the most important things you can do to preserve the radio controlled aircraft hobby are to avoid flying near full-scale aircraft and avoid flying near or over groups of people.

## IMPORTANT SAFETY PRECAUTIONS

1. Your Shoestring .46 ARF should not be considered a toy, but rather a sophisticated, working model that functions very much like a full-size airplane. Because of its performance capabilities, the Shoestring, if not assembled and operated correctly, could possibly cause injury to yourself or spectators and damage to property.

2. You must assemble the model **according to the instructions**. Do not alter or modify the model, as doing so may result in an unsafe or unflyable model. In a few cases the instructions may differ slightly from the photos. In those instances the written instructions should be considered as correct.

3. You must take time to build **straight, true** and **strong**.

4. You must use an R/C radio system that is in first-class condition, and a correctly sized engine and components (fuel tank, wheels, etc.) throughout the building process.

5. You must correctly install all R/C and other components so that the model operates correctly on the ground and in the air.

6. You must check the operation of the model before **every** flight to insure that all equipment is operating and that the model has remained structurally sound. Be sure to check clevises or other connectors often and replace them if they show any signs of wear or fatigue.

7. If you are not an experienced pilot or have not flown this type of model before, we recommend that you get the assistance of an experienced pilot in your R/C club for your first flights. If you're not a member of a club, your local hobby shop has information about clubs in your area whose membership includes experienced pilots.

8. While this kit has been flight tested to exceed normal use, if the plane will be used for extremely high stress flying, such as racing, or if an engine larger than one in the recommended range is used, the modeler is responsible for taking steps to reinforce the high stress points and/or substituting hardware more suitable for the increased stress.

9. **WARNING:** The cowl, wheel pants, and fuselage included in this kit are made of fiberglass, the fibers of which may cause eye, skin and respiratory tract irritation. Never blow into a part to remove fiberglass dust, as the dust will blow back into your eyes. Always wear safety goggles, a particle mask and rubber gloves when grinding, drilling and sanding fiberglass parts. Vacuum the parts and the work area thoroughly after working with fiberglass parts.

We, as the kit manufacturer, provide you with a top quality, thoroughly tested kit and instructions, but ultimately the quality and flyability of your finished model depends on how you build it; therefore, we cannot in any way guarantee the performance of your completed model, and no representations are expressed or implied as to the performance or safety of your completed model.

**Remember: Take your time and follow the instructions to end up with a well-built model that is straight and true.**

## DECISIONS YOU MUST MAKE

This is a partial list of items required to finish the Shoestring .46 ARF that may require planning or decision making before starting to build. Order numbers are provided in parentheses.

### Radio Equipment

*The Shoestring .46 ARF requires a minimum 4-channel radio system with four 44 oz.-in. [3.2 kg-cm] minimum standard sized servos. If you are installing a glow engine, an additional standard servo is required for the throttle.*

*In addition, two 6" [152mm] servo extensions are required for the aileron servos. If you are using a radio system that does not support mixing functions, Y-harnesses will also be required to connect the aileron servos to the receiver.*

*If you plan to install a brushless motor, you will need a 6" [152mm] servo extension for the ESC.*

*A charge jack receptacle is optional, but is useful for recharging the receiver pack without removing the canopy hatch. Recommended part numbers for the radio components are provided below:*

- Futaba® S9001 Servo Aircraft Coreless BB (FUTM0075)
- Hobbico® Pro™ HD Extension 6" [152mm] Futaba J (HCAM2701)
- Hobbico Pro HD Y-Harness Futaba J (HCAM2751)
- Ernst Charge Receptacle Futaba J FM (ERNM3001)

### Power System Recommendations

*The recommended engine/motor size for the Shoestring .46 ARF is a .46 – .55 cu in [7 – 9 cc] two-stroke engine, a .70 – .81 cu in [11.5-13.5 cc] four-stroke engine, or a RimFire .46 (42-60-800) brushless outrunner motor. Engine and motor order numbers are provided below:*

- O.S.® 46AX ABL w/Muffler (OSMG0547)
- Bisson O.S. .46 SF/FX .50 SX Pitts Muffler (BISG4046)
- Great Planes RimFire .46 (42-60-800) Outrunner Brushless (GPMG4725)
- Great Planes Brushless Motor Mount Medium Motors (GPMG1255)

*If using the recommended brushless motor, a 80A brushless ESC is required:*

- Great Planes Silver Series 80A Brushless ESC High Volt (GPM1860)

## Propeller

If you are installing a glow engine, choose a prop based on the engine manufacturer's recommendation. If you are installing the recommended RimFire brushless motor, we suggest an APC 11x5.5E propeller (APCQ1055).

## Batteries and Charger

For a brushless motor installation, two 3350mAh 11.1V Lithium Polymer battery packs connected in series are recommended. Order numbers for the battery packs and series connector are provided below:

- Great Planes LiPo 3350mAh 11.1V 25C Discharge w/Balance (GPMP0541)
- Great Planes Series Deans® U 2 to 1 Adapter (GPMM3143)

A cell balancer is required for the LiPo battery listed above:

- Great Planes ElectriFly™ Equinox™ LiPo Cell Balancer 1-5 (GPMM3160)

A suitable charger is also required. The Great Planes PolyCharge4™ is designed for LiPo packs only, but is able to charge four LiPo packs simultaneously. The Great Planes Triton2™ charger will only charge one pack at a time, but is capable of charging NiCd, NiMH, LiPo, and Pb acid batteries. Order numbers for both are provided below:

- Great Planes PolyCharge4 DC Only 4 Output LiPo Charger (GPMM3015)
- OR**
- Great Planes ElectriFly Triton2 DC Comp Peak Charger (GPMM3153)

## ADDITIONAL ITEMS REQUIRED

### Required Hardware and Accessories

This is the list of hardware and accessories required to finish the Shoestring .46 ARF. Order numbers are provided in parentheses:

- R/C foam rubber (1/4" [6mm] - HCAQ1000, or 1/2" [13mm] - HCAQ1050)
- 3' [900mm] standard silicone fuel tubing (GPMQ4131) (glow engine only)

## Adhesives and Building Supplies

This is the list of Adhesives and Building Supplies that are required to finish the Shoestring .46 ARF:

- 1/2 oz. [15g] Thin Pro™ CA (GPMR6001)
- 1/2 oz. [15g] Thick Pro CA- (GPMR6013)
- Pro 30-minute epoxy (GPMR6047)
- Threadlocker thread locking cement (GPMR6060)
- Denatured alcohol (for epoxy clean up)
- Drill bits: 1/16" [1.6mm], 5/64" [2mm], 3/32" [2.4mm], 3/16" [4.8mm], 1/4" [6.4mm]
- Great Planes Tap & Drill Set 6-32 (GPMR8102) (Glow engine installation only)
- Tap handle (GPMR8120) (Glow engine installation only)
- Rotary tool with cutting bit
- #1 Hobby knife (HCAR0105)
- #11 blades (XACR3111)
- Medium T-pins (100, HCAR5150)
- Top Flite® MonoKote® sealing iron (TOPR2100)
- Top Flite Hot Sock™ iron cover (TOPR2175)
- 220 grit sandpaper
- Panel Line Pen (TOPQ2510)

## Optional Supplies and Tools

Here is a list of optional tools that will help you build the Shoestring .46 ARF:

- 1/2 oz. [15g] Medium Pro CA+ (GPMR6007)
- 2 oz. [57g] spray CA activator (GPMR6035)
- 4 oz. [113g] aerosol CA activator (GPMR6034)
- CA applicator tips (HCAR3780)
- CA debonder (GPMR6039)
- Pro 6-minute epoxy (GPMR6045)
- Epoxy brushes 6, (GPMR8060)
- Mixing sticks (GPMR8055)
- Mixing cups (GPMR8056)
- Pliers with wire cutter (HCAR0630)
- Harry Higley's 3/16" Extended Drill (HIGR1020)
- Rotary tool reinforced cut-off wheel (GPMR8200)
- Servo horn drill (HCAR0698)
- Hobby Heat™ micro torch II (HCAR0755)
- Dead Center™ Engine Mount Hole Locator (GPMR8130)
- Precision Magnetic Prop Balancer (TOPQ5700)
- AccuThrow™ Deflection Gauge (GPMR2405)
- CG Machine™ (GPMR2400)
- Hobbico Flexible 18" Ruler Stainless Steel (HCAR0460)
- Top Flite MonoKote trim seal iron (TOPR2200)
- Top Flite MonoKote heat gun (TOPR2000)
- Hobbico Pin Vise 1/16 Collet w/6 Bits (HCAR0696)

- Hobbico 8-Piece Ball Tip Hex L Wrench SAE (HCAR0520)
- Hobbico 7-Piece Ball Tip Hex L Wrench Metric (HCAR0521)
- Great Planes Clevis Installation Tool (GPMR8030)

### Building Stand

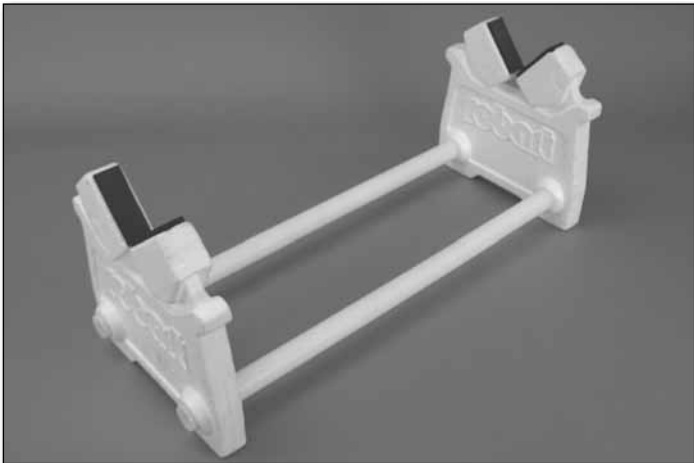

A building stand or cradle comes in handy during the build. We use the Robart Super Stand II (ROBP1402) for all our projects in R&D, and it can be seen in pictures throughout this manual.

### IMPORTANT BUILDING NOTES

- When you see the term **test fit** in the instructions, it means that you should first position the part on the assembly **without using any glue**, then slightly modify or *custom fit* the part as necessary for the best fit.
- Whenever the term **glue** is written you should rely upon your experience to decide what type of glue to use. When a specific type of adhesive works best for that step, the instructions will make a recommendation.
- Whenever just **epoxy** is specified you may use **either** 30-minute (or 45-minute) epoxy **or** 6-minute epoxy. When 30-minute epoxy is specified it is **highly** recommended that you use only 30-minute (or 45-minute) epoxy, because you will need the working time and/or the additional strength.
- **Photos** and **sketches** are placed **before** the step they refer to. Frequently you can study photos in following steps to get another view of the same parts.
- The stabilizer and wing incidences and engine thrust angles have been factory-built into this model. However, some technically-minded modelers may wish to check these measurements anyway. To view this information visit the web site at [www.greatplanes.com](http://www.greatplanes.com) and click on "Technical Data." Due to manufacturing tolerances which will have little or no effect on the way your model will fly, please expect slight deviations between your model and the published values.

### ORDERING REPLACEMENT PARTS

Replacement parts for the Great Planes Shoestring .46 ARF are available using the order numbers in the Replacement Parts List that follows. The fastest, most economical service can be provided by your hobby dealer or mail-order company.

To locate a hobby dealer, visit the Hobbico web site at [www.greatplanes.com](http://www.greatplanes.com). Choose "Where to Buy" and follow the instructions provided on the page to locate a U.S., Canadian or International dealer.

Parts may also be ordered directly from Hobby Services by calling (217) 398-0007, or via facsimile at (217) 398-7721, but full retail prices and shipping and handling charges will apply. Illinois and Nevada residents will also be charged sales tax. If ordering via fax, include a Visa® or MasterCard® number and expiration date for payment.

Mail parts orders and payments by personal check to:

Hobby Services  
3002 N Apollo Drive, Suite 1  
Champaign IL 61822

Be certain to specify the order number exactly as listed in the Replacement Parts List. Payment by credit card or personal check only; no C.O.D.

If additional assistance is required for any reason contact Product Support by e-mail at [productsupport@greatplanes.com](mailto:productsupport@greatplanes.com), or by telephone at (217) 398-8970.

#### REPLACEMENT PARTS LIST

Order No.	Description
GPMA3390	Fuselage
GPMA3391	Wing Set
GPMA3392	Tail Set
GPMA3393	Canopy/Hatch
GPMA3394	Cowl
GPMA3395	Landing Gear
GPMA3396	Wheel Pants
GPMA3397	Wing Tube
GPMA3398	Decal
<b>NOTE</b> ▶	Full-size plans are not available. You can download a copy of this manual at <a href="http://www.greatplanes.com">www.greatplanes.com</a> .

## KIT INSPECTION

Before starting to build, take an inventory of this kit to make sure it is complete, and inspect the parts to make sure they are of acceptable quality. If any parts are missing or are not of acceptable quality, or if you need assistance with assembly, contact **Product Support**.

Great Planes Product Support  
3002 N Apollo Drive, Suite 1  
Champaign, IL 61822  
Telephone: (217) 398-8970, ext. 5  
Fax: (217) 398-7721  
E-mail: [airsupport@greatplanes.com](mailto:airsupport@greatplanes.com)

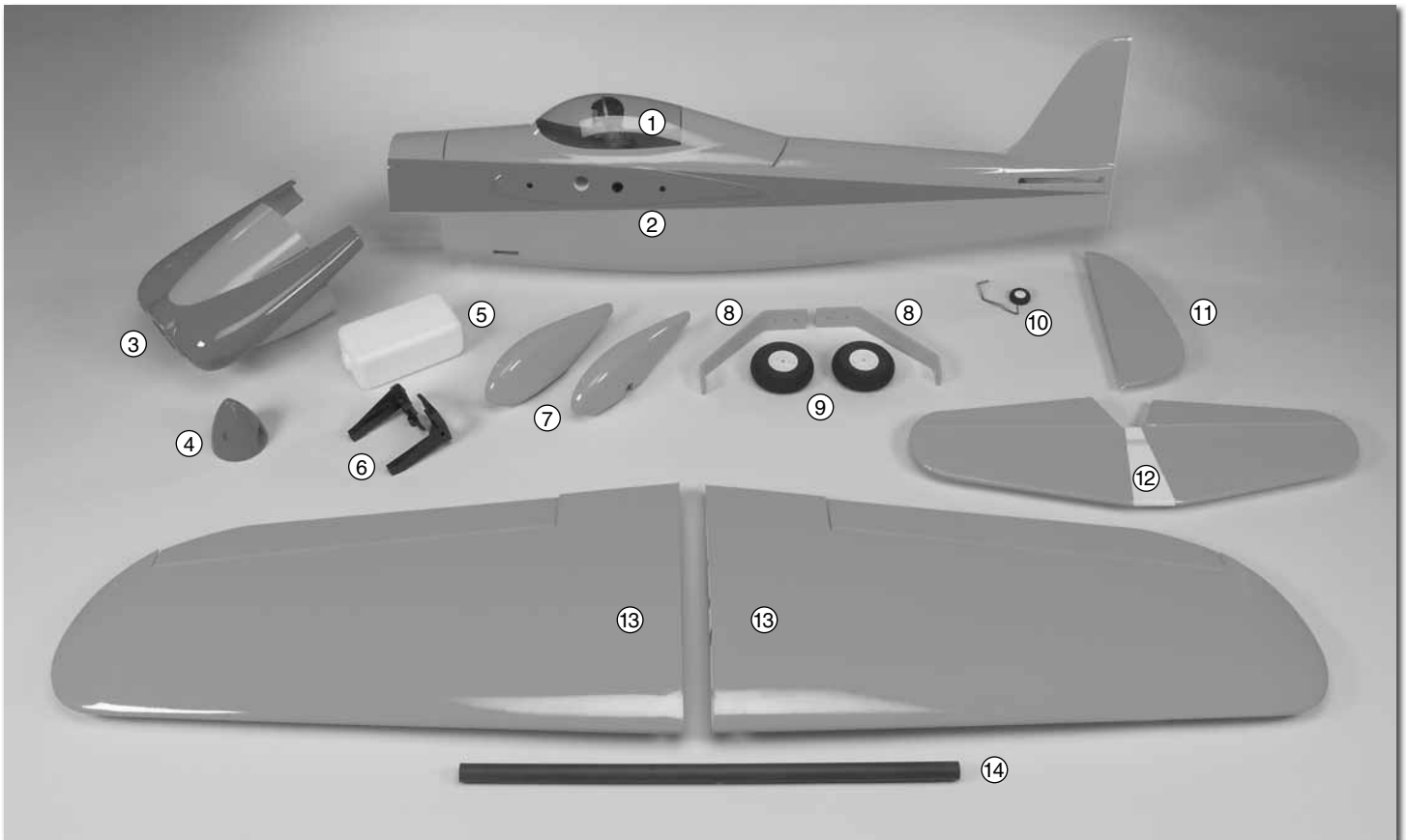

- |                        |                           |
|------------------------|---------------------------|
| 1. Canopy/Hatch        | 8. Main Landing Gear (2)  |
| 2. Fuselage            | 9. Main Wheels (2)        |
| 3. Cowl                | 10. Tail Wheel Assembly   |
| 4. Spinner             | 11. Rudder                |
| 5. Fuel Tank           | 12. Horizontal Stabilizer |
| 6. Engine Mount Halves | 13. Wing Halves           |
| 7. Wheel Pants (2)     | 14. Wing Joiner Tube      |

## PREPARATIONS

- ❑ 1. If you have not done so already, remove the major parts of the kit from the box and inspect for damage. If any parts are damaged or missing, contact Product Support at the address or telephone number listed in the "Kit Inspection" section on page 6.



- ❑ 2. Remove the tape and separate all the control surfaces. Use a covering iron with a covering sock on high heat to tighten the covering if necessary. Apply pressure over sheeted areas to **thoroughly** bond the covering to the wood.

## ASSEMBLE THE WINGS

Before completing this section, confirm that the servos that you will be using will properly fit between the servo mounting blocks on the aileron servo hatch covers. Make adjustments as necessary for your brand servos. A razor saw or hobby knife can be used to trim the blocks if necessary.

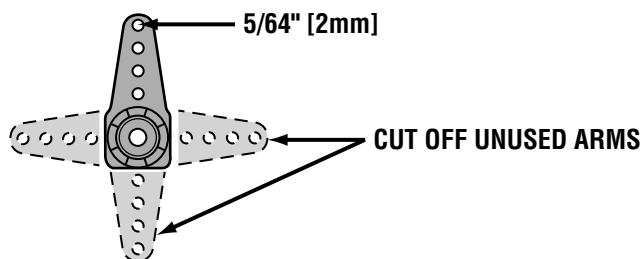

- ❑ 1. Cut three arms from a four-armed servo arm for each aileron servo. Enlarge the outer hole of each remaining arm with a 5/64" [2mm] drill bit.

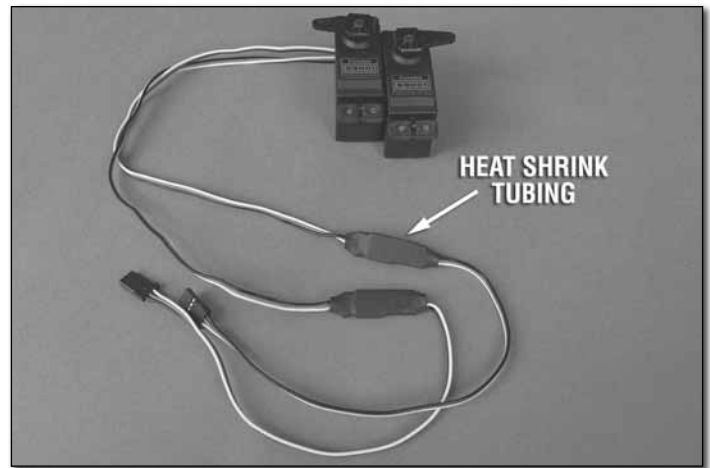

- ❑ 2. Attach a 6" [152mm] servo extension to each aileron servo and secure the connector using 1-1/2" [38mm] pieces from the included heat shrink tubing. Center the servos with your radio system and install the servo arms to the servos perpendicular to the servo cases as shown. Be sure to reinstall the servo arm screws into the servos.

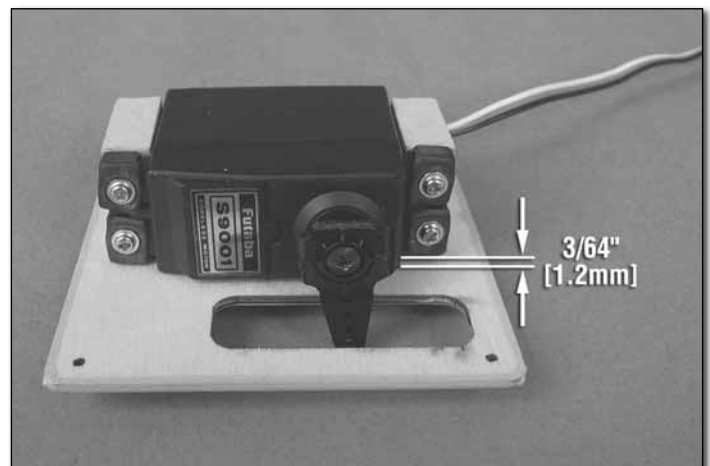

- ❑ 3. Position the servos against the underside of the aileron servo hatch covers between the mounting blocks. Shim the servo away from the hatch cover approximately 3/64" [1.2mm] (a business card folded in thirds works well for this). Drill 1/16" [1.6mm] holes through the mounting tabs on the servo cases into the blocks. Thread a servo mounting screw (included with the servo) into each hole and back it out. Apply a drop of thin CA to each hole to harden the wood. When the CA has dried, install the servos onto the hatch covers using the hardware supplied with the servos.

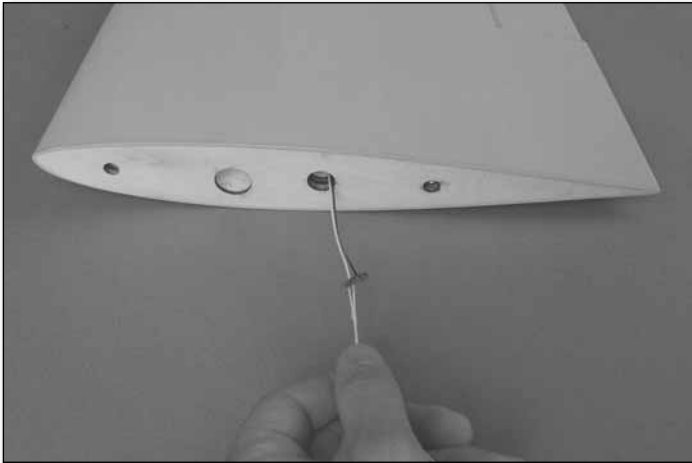
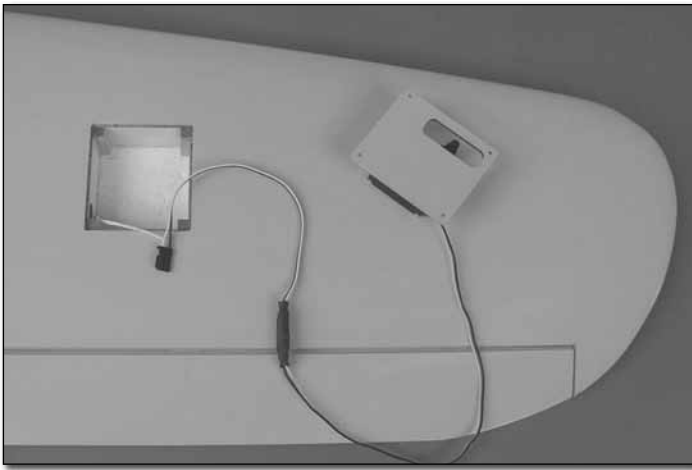

❑ 4. Use the strings taped inside the aileron servo hatches to pull the servo leads through the wing.

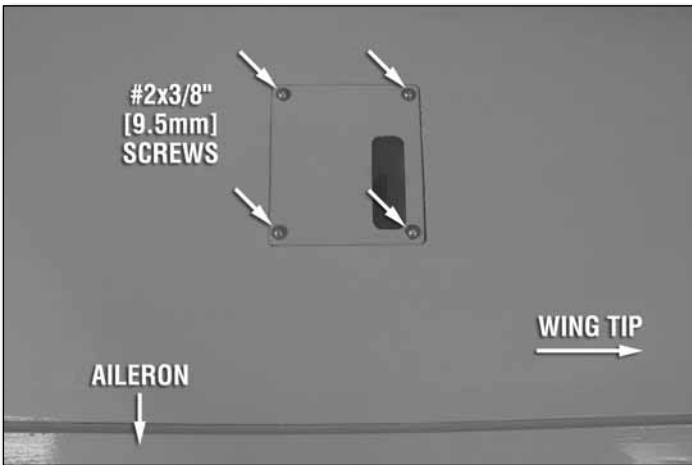

❑ 5. Position the aileron servo hatch covers in place and drill a 1/16" [1.6mm] hole through the mounting holes and into the hatch mounting blocks. Thread a #2 x 3/8" [9.5mm] self-tapping screw into each hole and back it out. Apply a drop of thin CA to each hole to harden the wood surrounding the hole. Install the hatch covers to the wings using eight #2 x 3/8" [9.5mm] self-tapping screws and eight #2 flat washers.

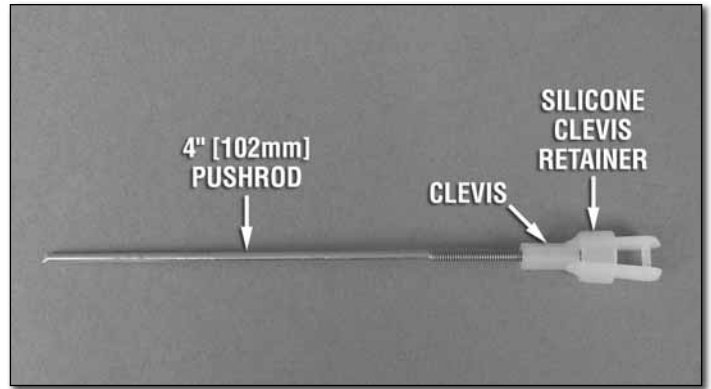

❑ 6. Thread a nylon clevis 20 complete turns onto each 4" [102mm] pushrod. Slide a silicone clevis retainer onto each clevis and connect the clevises to the outer holes of two control horns.

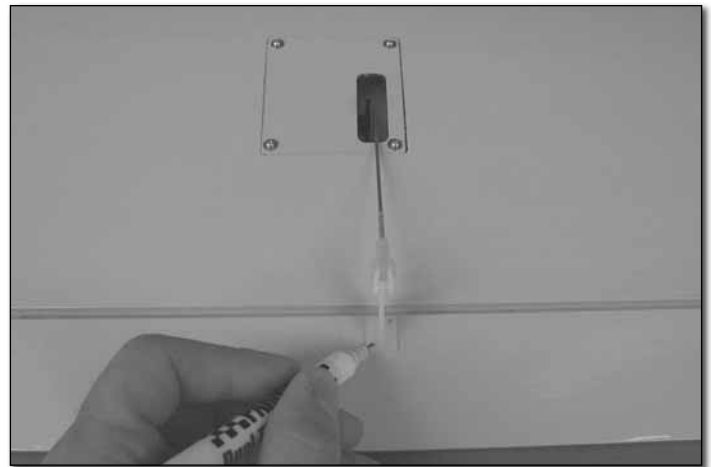
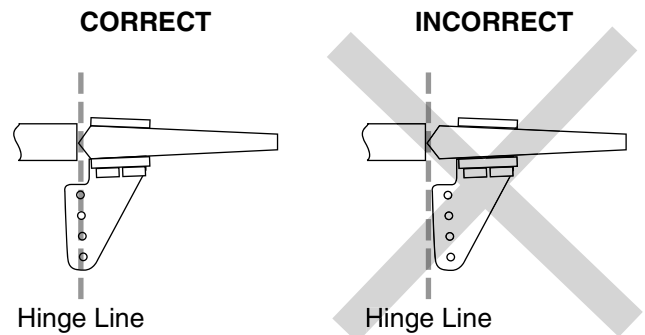

❑ 7. Position the control horns over the plywood plates in the **ailerons** (if you cannot see them, hold the aileron at a shallow angle in good lighting or use a small pin to puncture the covering) using the position of the servo arms as a guide. Align the holes in the control horns directly over the aileron hinge line and mark the location of the control horn mounting holes.

❑ 8. Drill 1/16" [1.6mm] holes at the marks you made through the plywood plates. Do not drill all the way through the ailerons! Thread a #2 x 1/2" [13mm] self-tapping screw through each hole and back it out. Apply a couple drops of thin CA glue to each hole to harden the wood. When the glue has dried, install the control horns onto the ailerons using four #2 x 1/2" [13mm] self-tapping screws.



## ASSEMBLE THE TAIL SECTION

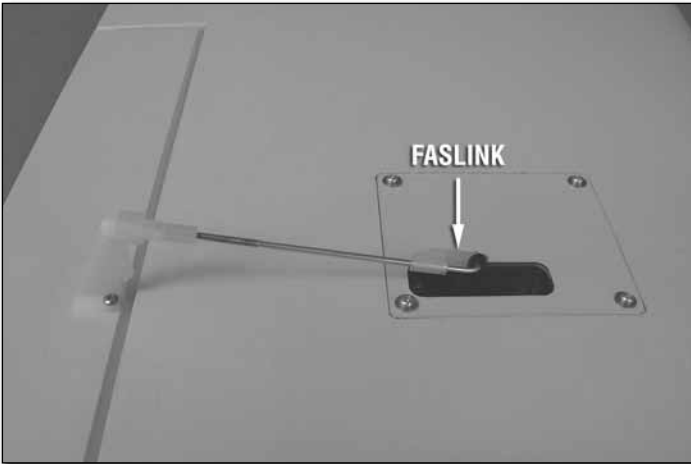
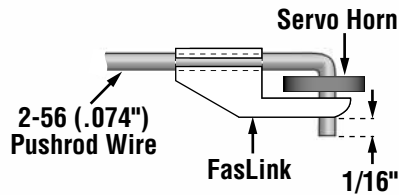
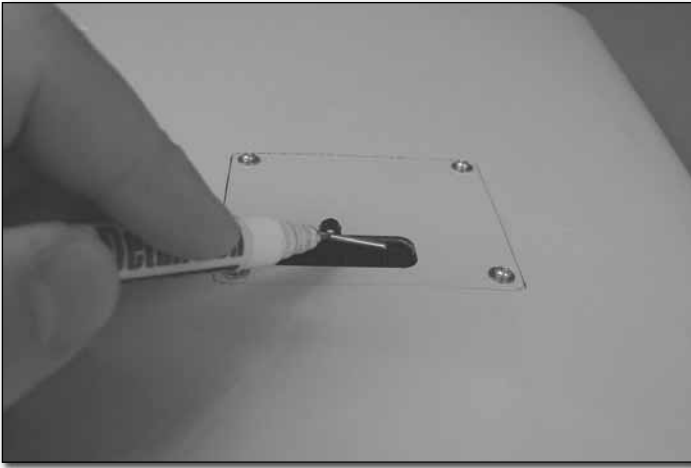

9. Use tape or a small clamp to hold the ailerons in the neutral position. Make a mark on the pushrods where they cross the outer holes in the servo arms. Make a 90° bend at the mark on the pushrod and cut off the excess pushrod 1/4" [6mm] beyond the bend. Attach the pushrods to the servo arms using nylon FasLinks. Thread the clevises up or down on the pushrods as necessary to center the ailerons with the servo arms centered. When satisfied, slide the silicone clevis retainers to the ends of the clevises to secure them.

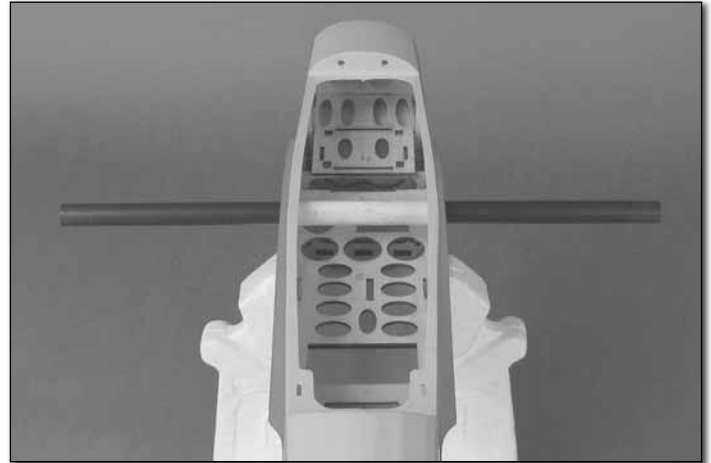

1. Insert the **wing tube** into the **fuselage** and center its position. Slide the wing panels onto the tube and feed the aileron servo leads through the mating holes in the fuse. Tighten the wing panels against the fuse using the two nylon wing bolts.

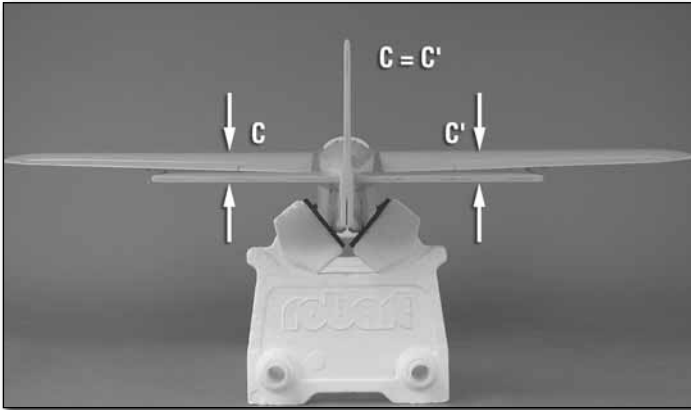
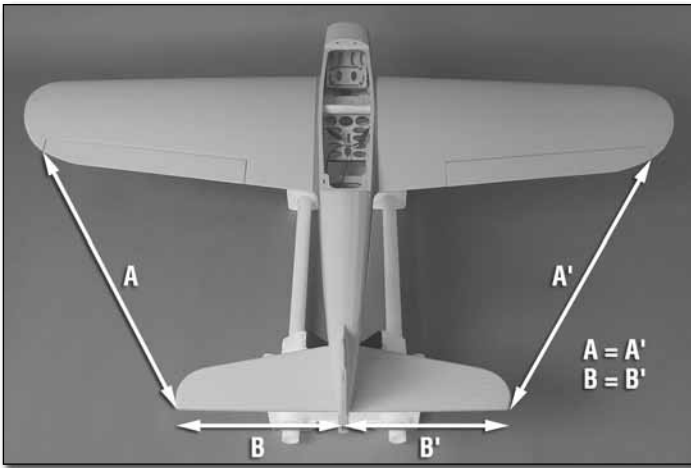

❑ 2. Test fit the **horizontal stabilizer** into the stab slot at the aft end of the fuselage (without glue). Center the stab left and right in the fuse. Measure the distance from the stab tips to the wing tips and make the measurements equal. Now, stand behind the model approximately 5-6 ft [1.5-1.8m] and confirm that the stab and wings are parallel. If not, weight can be added to one side to bring them parallel, or the stab can be taped to the fin to pull it parallel with the wing.

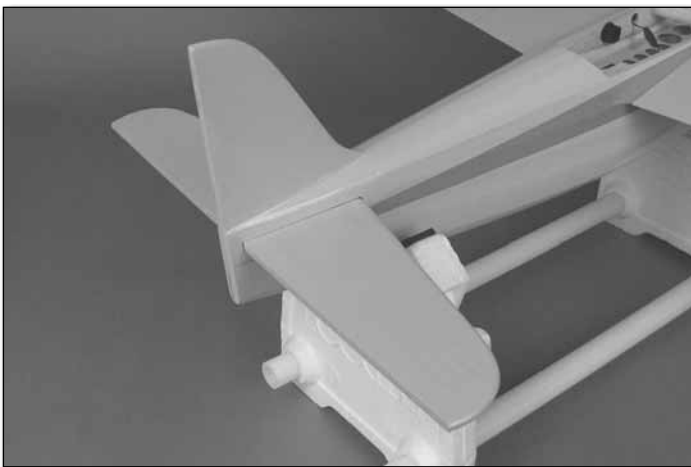

❑ 3. After you have determined if any weight will need to be added during the gluing process, remove the stab from the fuse. If necessary, lightly sand away any excess paint from inside the stab slot. Mix up a batch of 30-minute epoxy and coat the stab slot as well as the exposed wood of the stabilizer (coating the stab slot will require additional cleanup after inserting the stab into the fuse. However, it will make a stronger glue joint). Slide the stab into the fuse, center it left

and right and align it with the wing panels. Use denatured alcohol to clean up any excess epoxy. Allow the epoxy to cure undisturbed.

❑ 4. When the epoxy has cured, the wing panels can be removed from the fuselage and set aside. They will not be needed again until it is time to set up the control throws.

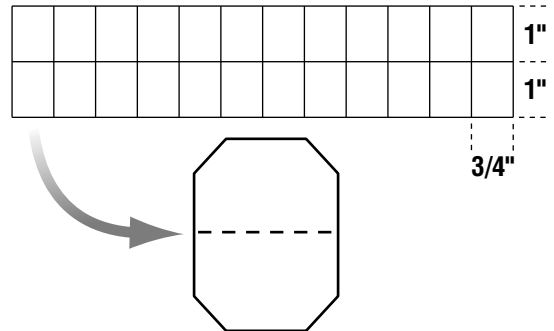

❑ 5. Cut the included 2" x 9" [51mm x 229mm] CA hinge strip into 3/4" x 1" [19mm x 25mm] individual hinges. Clip the corners of each hinge to make them easier to insert into the hinge slots.

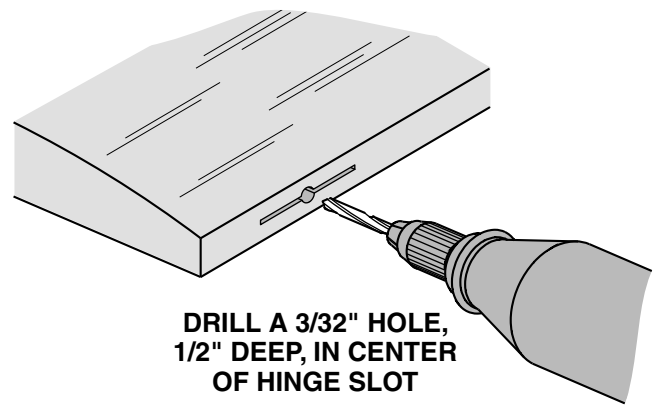

❑ 6. Drill a 3/32" [2.4mm] hole 1/2" [13mm] deep into the center of each hinge slot in the stab and **elevator halves**.

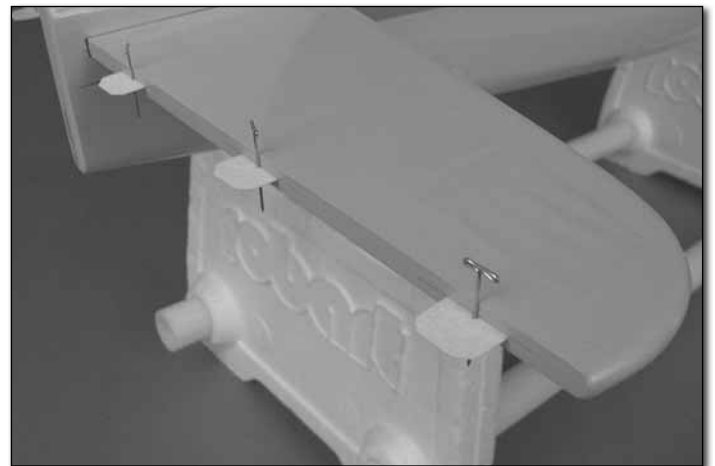

❑ 7. Test fit a CA hinge into each of the hinge slots in the stab and elevator halves. If necessary, enlarge the slots with a hobby knife. When satisfied with the fit, insert a CA hinge halfway into each hinge slot in the wing panel. Push a pin through the middle of each hinge to keep them centered.



❑ 8. Join the elevators to the stab and remove the pins from the hinges. Align the tips of the elevators with the stab tips. Adjust the elevators so there is a small gap between the LE of the elevators and the stab. The gap should be small, just enough to see light through the gap or to slip a piece of paper through. Apply six drops of thin CA to the top and bottom of each hinge without using accelerator. After the CA glue has hardened, confirm that the elevators are secure by pulling on them and deflecting them up and down.

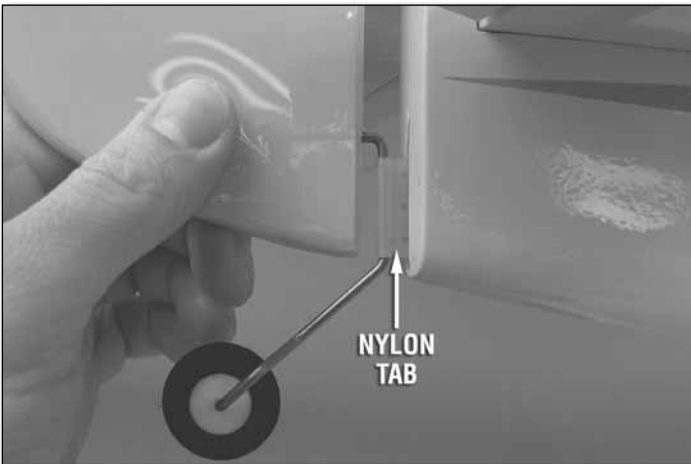

❑ 9. Test fit the rudder to the fuselage with the tail wheel assembly installed in the orientation shown. Make any adjustments necessary so the nylon tab on the tail wheel wire fits all the way into the slot in the fuse.

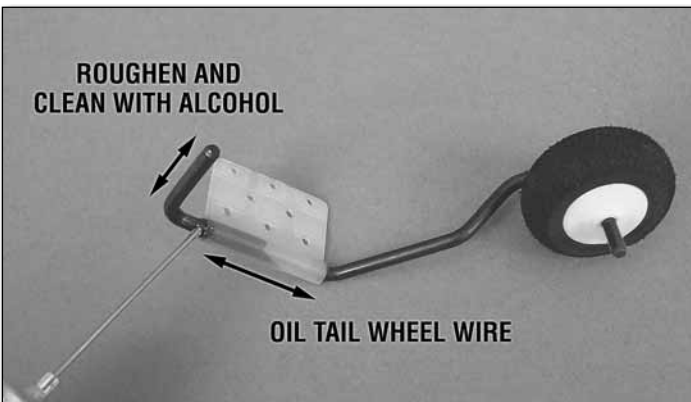

❑ 10. Roughen the portion of the tail wheel assembly that fits into the rudder with 220-grit sand paper and clean it off with alcohol. Oil the tail wheel wire at the nylon tab to prevent it from being glued to the wire.

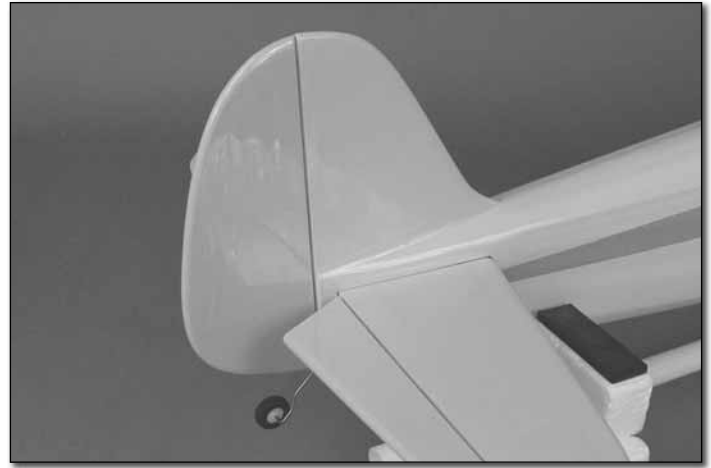

❑ 11. Glue the tail wheel wire into the hole in the LE of the rudder with medium or thick CA glue. Lightly coat both sides of the nylon tab with thick CA glue or epoxy and fit the rudder to the fuselage along with two CA hinges. Glue the CA hinges in place with thin CA glue.

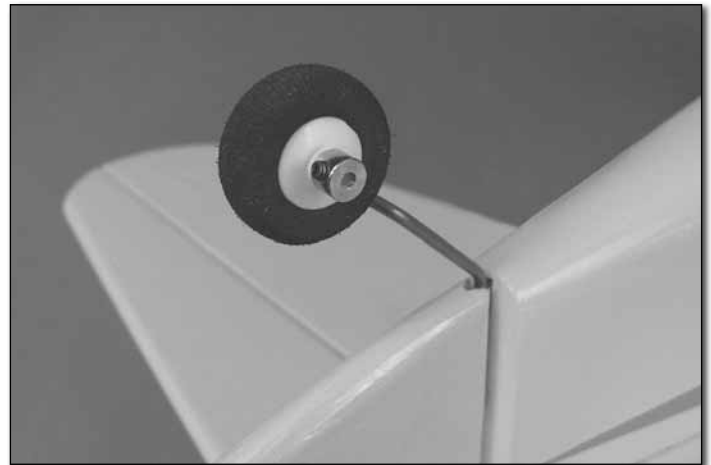

❑ 12. Secure the tail wheel onto the tail wheel wire with a 3/32" [2.4mm] wheel collar and a 4-40 set screw.

## INSTALL THE TAIL SERVOS AND PUSHRODS



1. Temporarily insert a 2-56 x 36" [914mm] pushrod into each elevator pushrod exit slot. Use the position of the pushrods to align the elevator control horns onto the undersides of the elevator halves. Mark the locations of the control horn mounting holes onto the elevator halves and drill 5/64" [2mm] holes at the marks. Attach the elevator control horns to the elevators using four 2-56 x 5/8" [16mm] machine screws and the control horn backplates.



2. Install a control horn onto the right side of the rudder in the same manner.

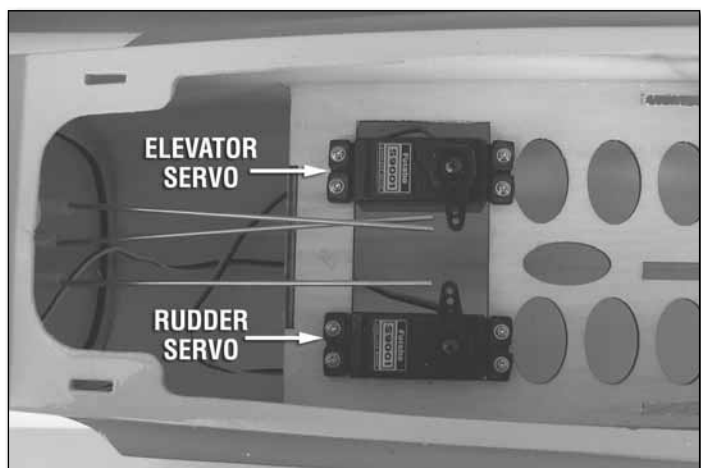

3. Install the elevator and rudder servos onto the servo tray in the direction and positions shown using the hardware supplied with the servos. Note that the pushrods are used to position the servos on the tray. Be sure to harden the screw holes with thin CA as was done with the aileron servos. Cut three arms from two four-armed servo arms. Center the servos with your radio system and install them onto the servos with the servo screws. Enlarge the outer holes of each servo arm with a 5/64" [2mm] drill bit.

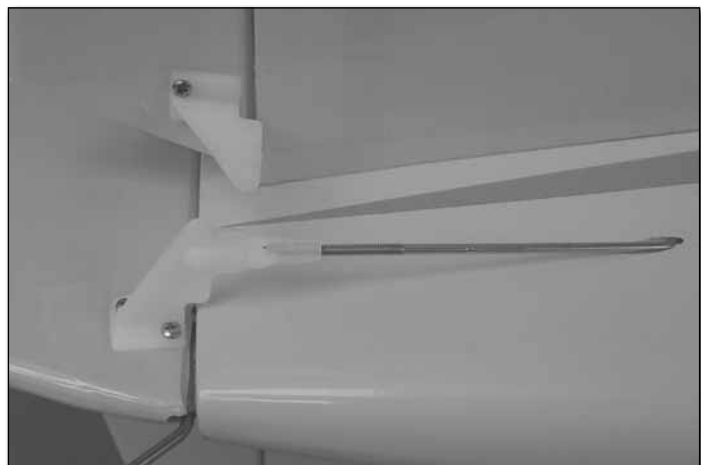

4. Thread a nylon clevis and silicone clevis retainer onto a 2-56 x 36" [914mm] pushrod 20 complete turns. Slide the

pushrod through the rudder pushrod exit slot in the fuselage and connect it to the third outer hole in the rudder control horn. Slide the silicone clevis retainer to the end of the clevis.



❑ 4. With the rudder in the neutral position and the rudder servo arm perpendicular to the servo case, mark where the pushrod crosses the outer hole of the servo arm. As you did with the aileron pushrods, make a 90° bend at the mark and cut off the excess pushrod 1/4" [6.4mm] beyond the bend. Secure the pushrod to the servo arm with a nylon FasLink. Make any adjustments necessary to the nylon clevis so that the rudder is properly centered and slide the silicone clevis retainer to the end of the clevis.

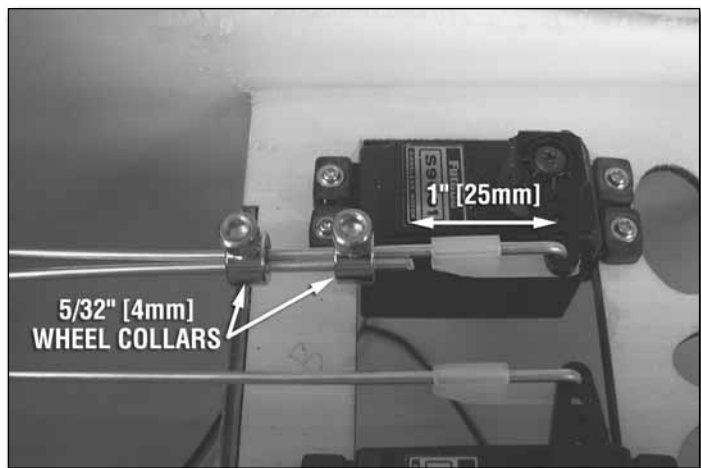

❑ 6. With the left elevator in the neutral position and the elevator servo arm perpendicular to the servo case, mark the location where the left elevator pushrod crosses the outer hole of the elevator servo arm. Make a 90 degree bend at the mark and cut off the excess pushrod 1/4" [6.4mm] beyond the bend. Position the right elevator in the neutral position and cut off the excess pushrod 1" [25mm] behind the elevator servo arm. Join the two elevator pushrods together using two 5/32" [4mm] wheel collars, two 6-32 x 1/4" [6.4mm] SHCS, and thread locking compound. View the model from behind and confirm that the elevator halves are parallel. If not, make any adjustments as necessary to the clevises or wheel collars until they are. Connect the left elevator pushrod to the servo arm with a FasLink.

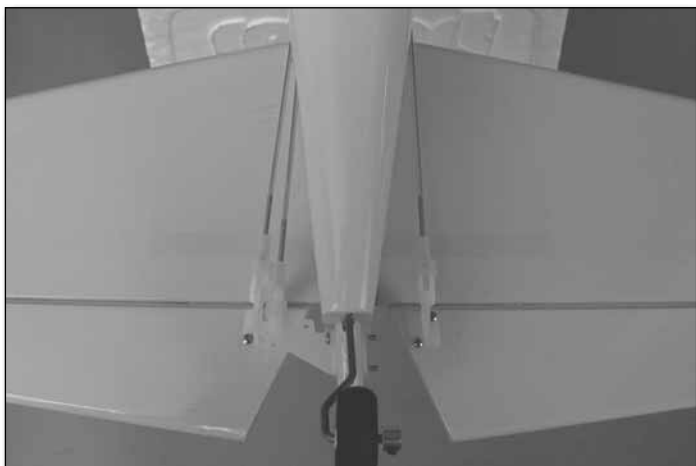

❑ 5. Connect two 2-56 x 36" [914mm] pushrods with nylon clevises and silicone clevis retainers to the third outer holes in the elevator control horns.

## ASSEMBLE AND INSTALL THE MAIN LANDING GEAR

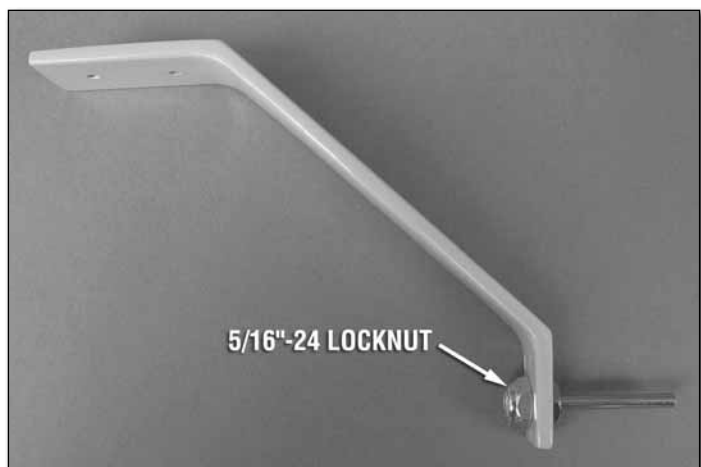

❑ 1. Secure the axles to the landing gear legs using the 5/16"-24 nylon lock nuts.

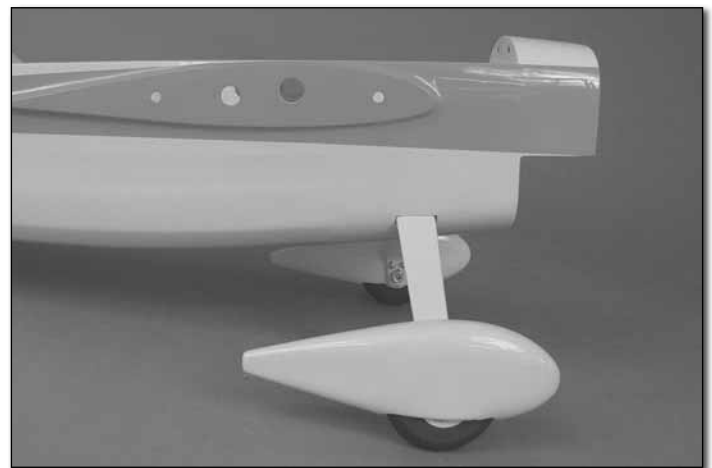
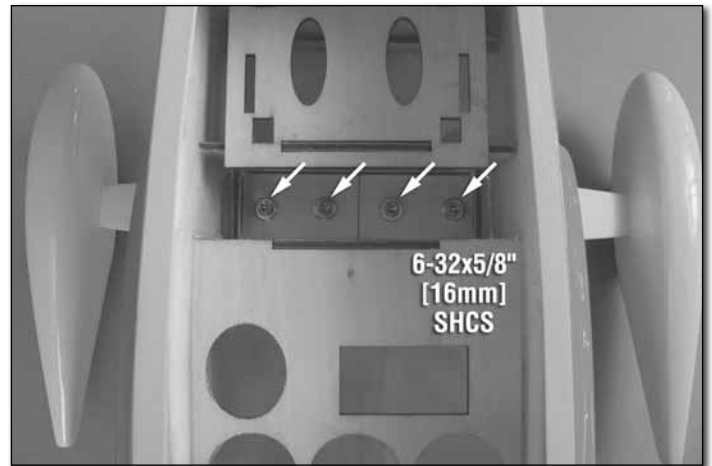
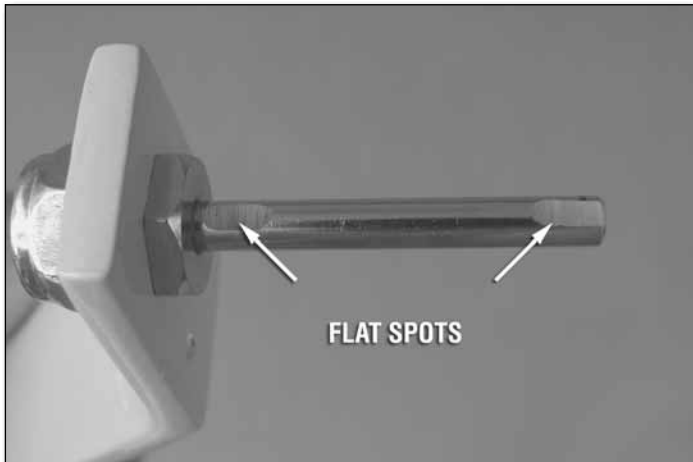
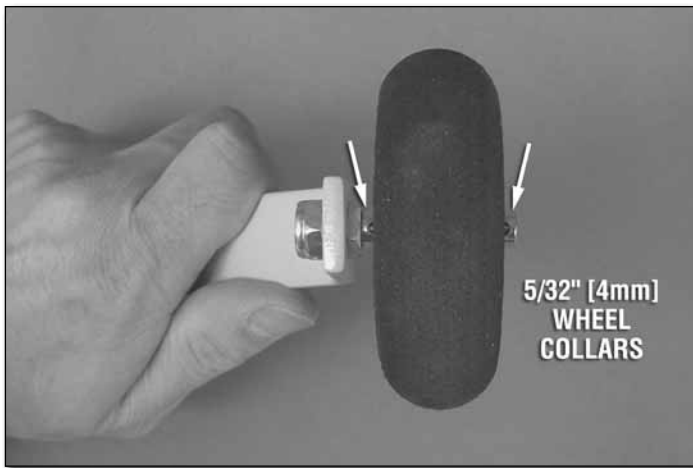

❑ 2. Slide a 5/32" [4mm] wheel collar onto each axle followed by a 3" [76mm] wheel and then another 5/32" [4mm] wheel collar. Mark the location of the threaded holes in the wheel collars onto the axles. Use a file or rotary tool such as a Dremel to grind flat spots at the marks on the axles.

❑ 3. Reinstall the wheel collars and wheels onto the axles. Thread a 6-32x1/4" [6.4mm] socket head cap screw into each wheel collar and tighten the screws against the flat spots on the axles using threadlocking compound. Be sure that the wheel rotates freely on the axle. Oil the axles if necessary.

❑ 5. Attach the landing gear legs to the fuselage using four 6-32 x 5/8" [16mm] SHCS, four #6 flat washers, four #6 lock washers, and thread locking compound.

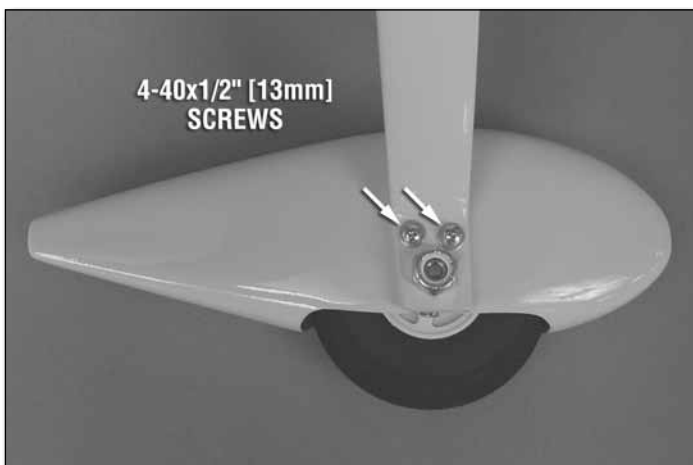

❑ 4. Attach the wheel pants to the landing gear legs using four 4-40 x 1/2" [13mm] machine screws, four #4 flat washers, four #4 lock washers, and thread locking compound.

## INSTALL THE POWER SYSTEM

### Glow Engine Installation

The Shoestring is designed to be flown with a .46 – .55 two-stroke glow engine, .70 – .81 four-stroke glow engine, or a brushless outrunner motor. If you plan to install a brushless motor, skip this section as it only contains information relevant to installing a glow engine.

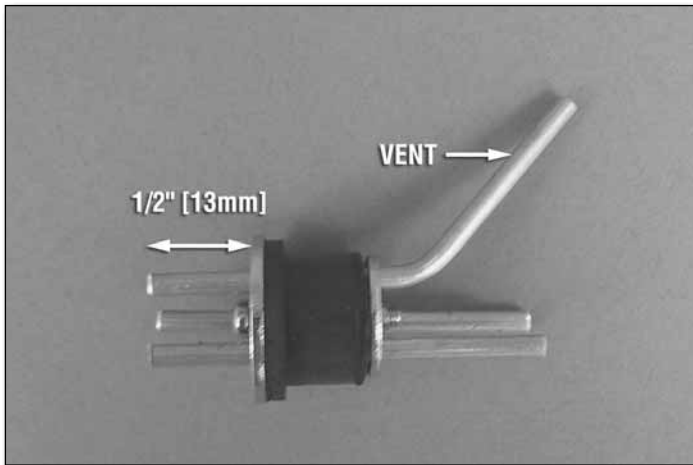
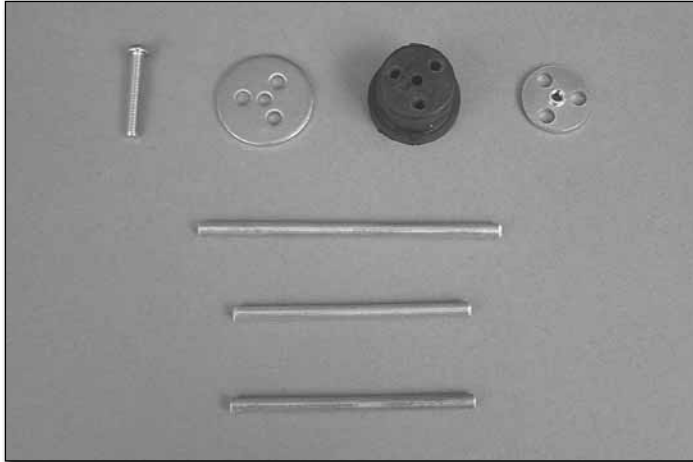

1. The fuel tank can be assembled as a two line system consisting of a vent (pressure) line to the muffler and a carb line. Filling and emptying of the tank would need to be done through the carb line, or an optional fuel fill valve (not included). The tank can also be assembled as a three line system having a vent line, carb line, and fill line. If installing a fill line, puncture the top of the stopper above the sealed off fuel tube hole. The front of the lines should extend out 1/2" [13mm] beyond the stopper and the vent line should be bent upwards and left uncut. With the tubes installed in the stopper, fit the stopper plates loosely in place with the 3 x 25mm phillips screw to hold the assembly together.

TOP OF TANK

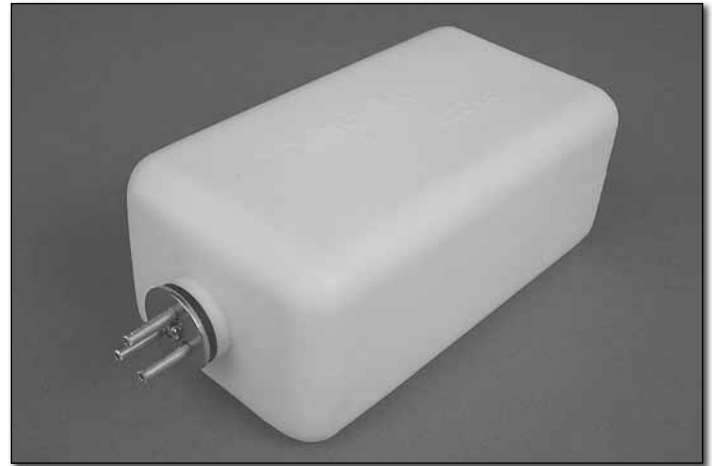
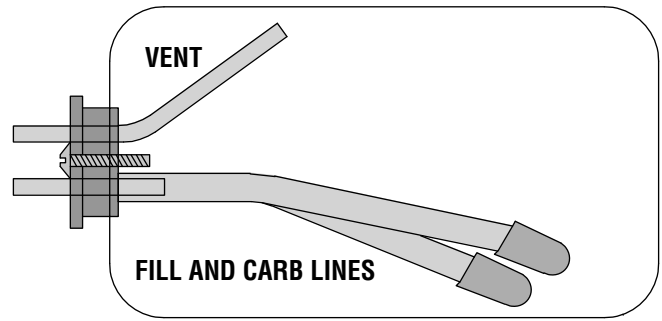

2. Fit the stopper assembly into the tank with the vent line pointing toward the top of the tank, but not touching. The fuel tubing and clunks (fuel pickup) on the carb and fill lines should almost reach the back of the tank but not touch. The clunks must be able to move freely inside the tank when assembled. Adjust the length of the fuel tubing accordingly. When satisfied, tighten the 3x25mm screw in the stopper to secure it in place (do not over-tighten). Mark the side of the tank that must face up when installed in the plane, and we also suggest marking the tubes in the stopper.

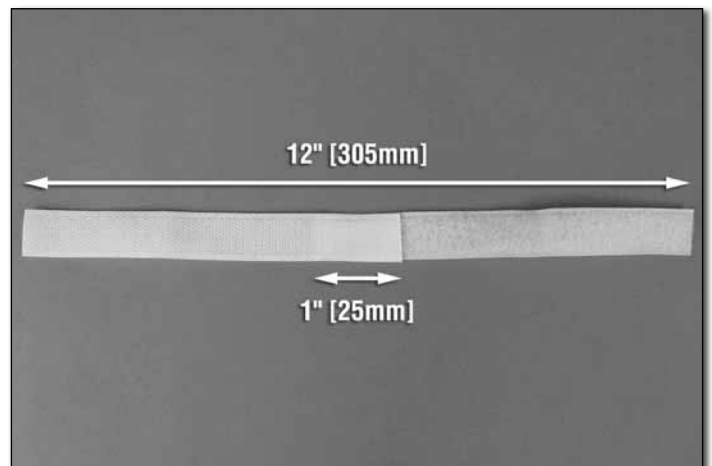

3. Make a 12" [305mm] strap from the included hook and loop material by overlapping the mating ends by approximately 1" [25mm].

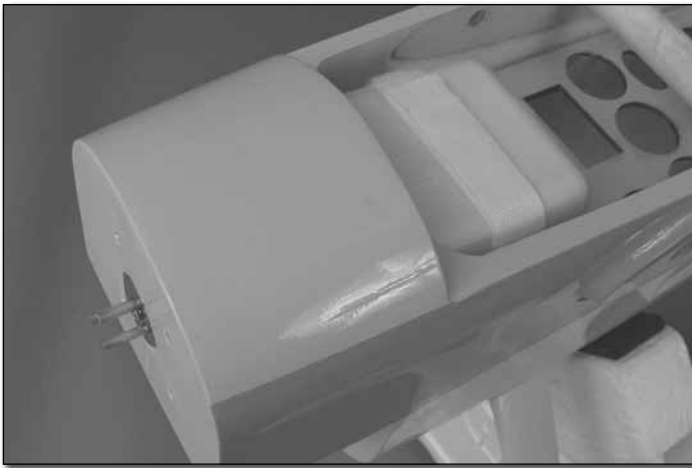

❑ 4. Insert the hook and loop through the slots in the fuel tank tray. Fit the tank neck through the hole in the firewall (with the correct side of the tank facing up) and use the strap to tightly secure the tank to the tray.



❑ 5. Cut the included 6x6mm stick to fit snugly between the fuse sides right behind the fuel tank. Glue the stick into place.

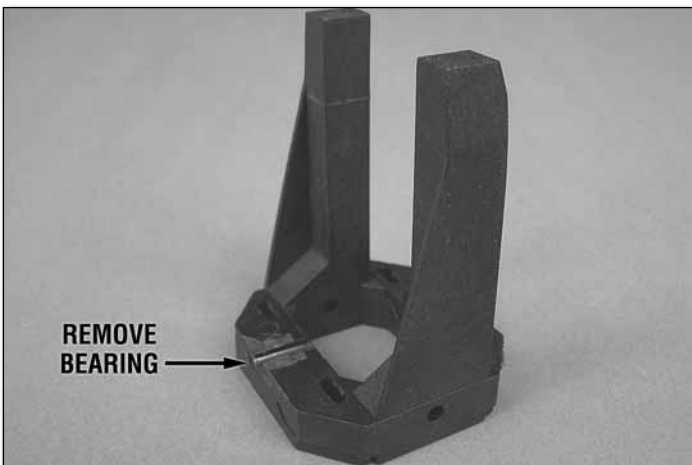

❑ 6. If you plan to install the O.S. 81FS-a engine, you will need to cut away the nose gear bearing from the engine mount as shown. A rotary tool with a sanding or cutting bit works well for this. A hobby knife can also be used.

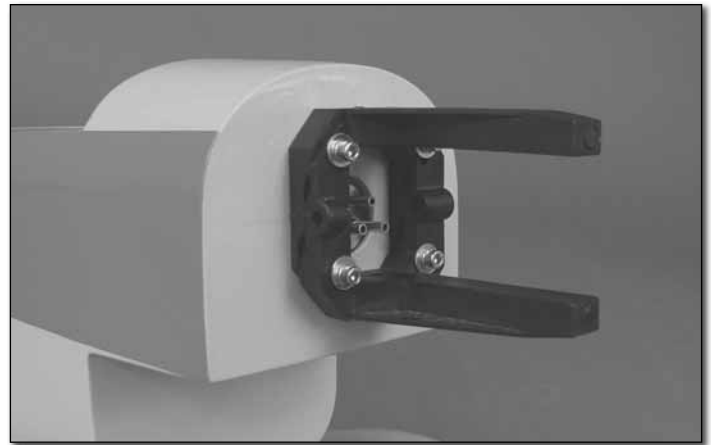

❑ 7. Using four 6-32 x 3/4" [19mm] SHCS, four #6 flat washers, four #6 lock washers, and thread locking compound, attach the engine mount side-mounted to the firewall so that the engine head will be on the right side. Leave the screws slightly loose. Test fit your engine between the mount halves. Slide the mount halves against the sides of the engine and finish tightening the mount screws.

❑ 8. Attach a 6"-7" [152mm-178mm] piece of fuel tubing onto each line coming from the tank.

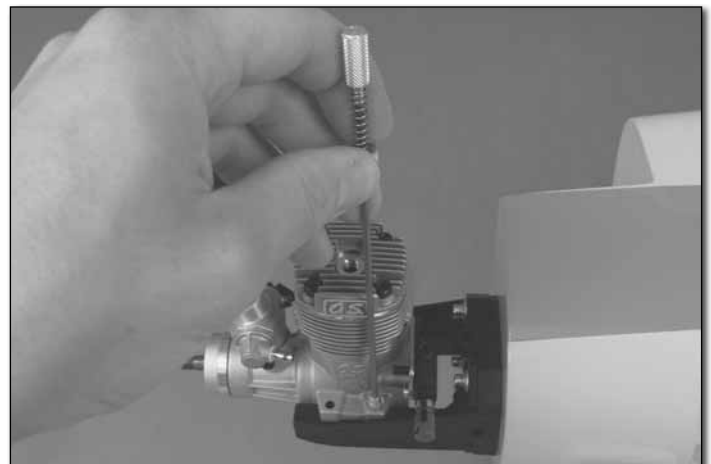
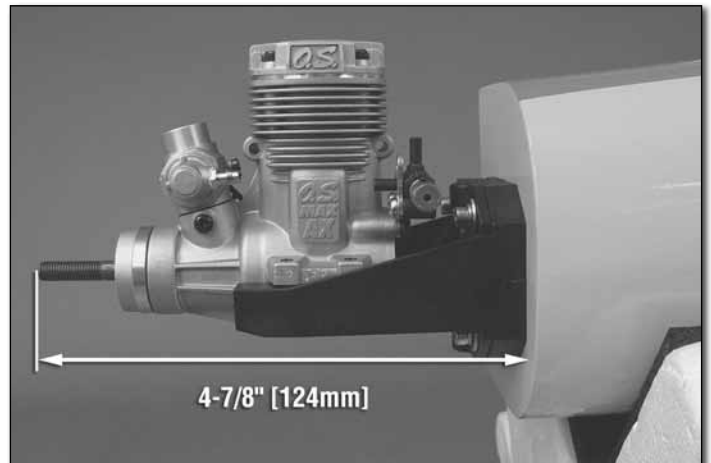

❑ 9. Position the front of the engine drive washer 4-7/8" [124mm] from the firewall. Mark the location of the engine mount holes onto the mount rails using a Dead Center Hole Locator. Remove the engine from the mount and use a 6-32 tap and drill set to create threads in the four mounting holes.



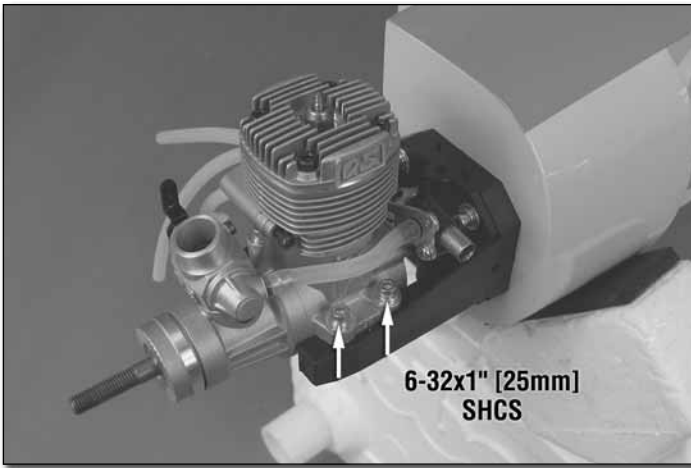

❑ 10. Attach the engine to the mount using four 6-32 x 1" [25mm] SHCS, four #6 flat washers, and four #6 lock washers.

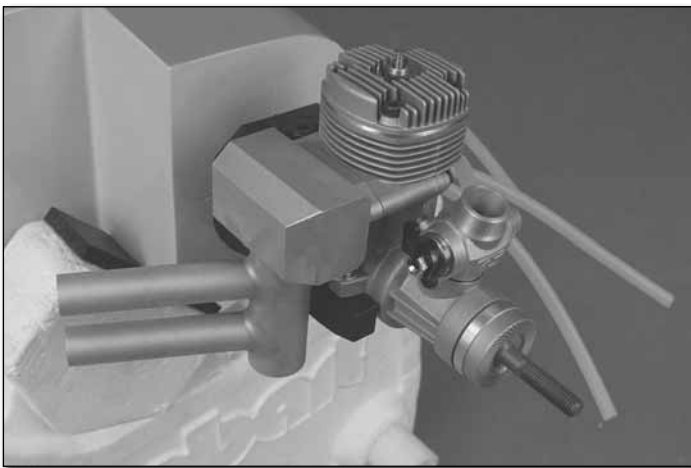

❑ 11. Install your muffler onto the engine. We are using a pitts-style muffler for a clean and easy installation. The stock muffler will also work, but a lot of the cowl will have to be trimmed away.

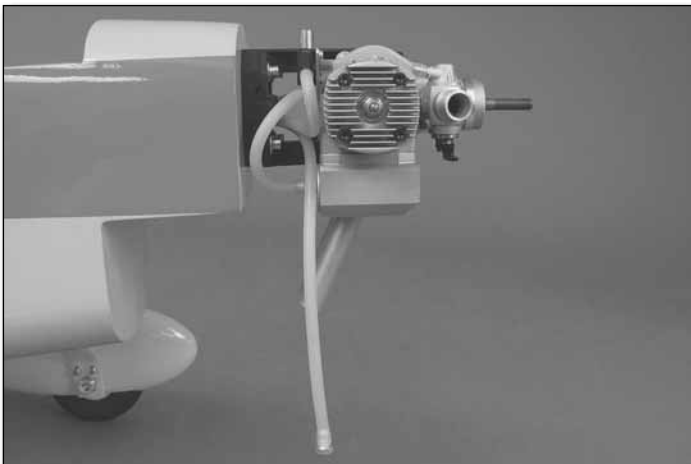

❑ 12. Cut the fuel tubing coming from the tank to the proper length and connect the pressure and carb lines to the engine. The fill line (if installed) should be plugged with the included aluminum fuel line plug and can be routed through a hole in the cowl which will be done later in the assembly (remember to replace the fuel line plug after filling or draining the fuel tank).

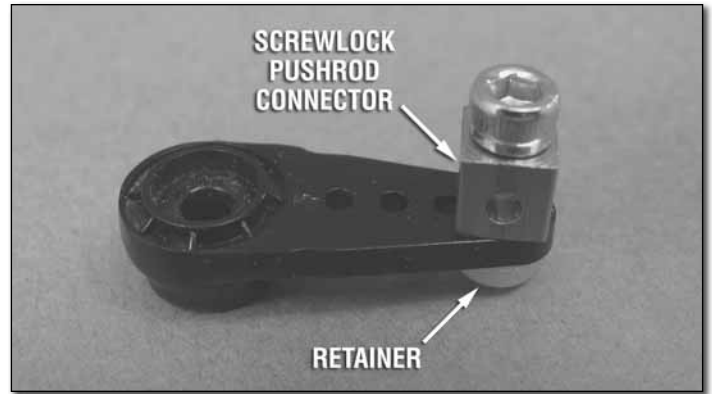

❑ 13. Cut three arms from a four-armed servo arm included with your throttle servo. Install a screw-lock pushrod connector into the outer hole in the remaining arm and secure it in place with a nylon pushrod connector retainer. Loosely install a 4-40 x 1/8" [3mm] SHCS into the screw-lock pushrod connector.

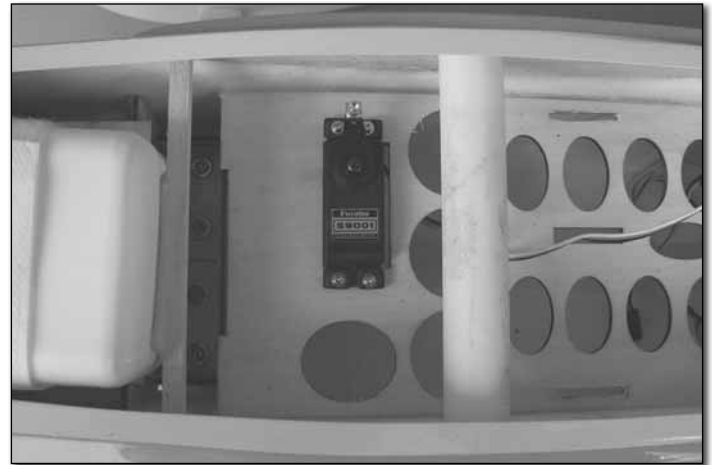

❑ 14. Center the throttle servo with your radio system and install the arm perpendicular to the servo case. Install the throttle servo onto the throttle servo tray using the hardware supplied with the servo. Most engine models will require the throttle servo to be oriented on the tray in the direction shown.

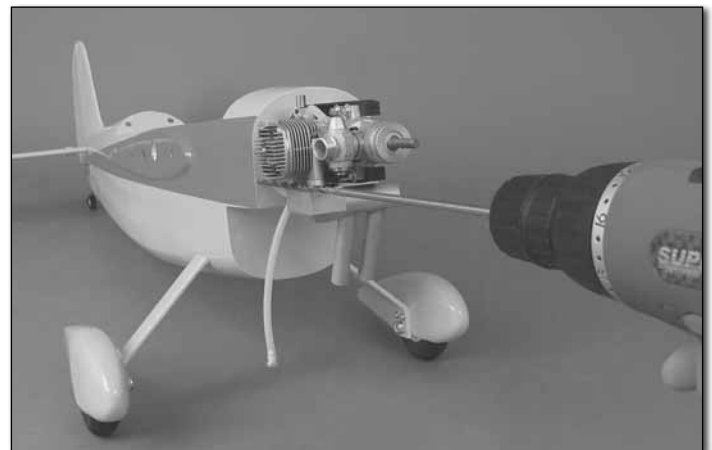

❑ 15. Drill a hole through the firewall using a 3/16" [4.8mm] drill bit (an extra long bit works well for this step) inline with the location of the throttle arm on the engine carburetor. Take care not to drill through the fuel tank!

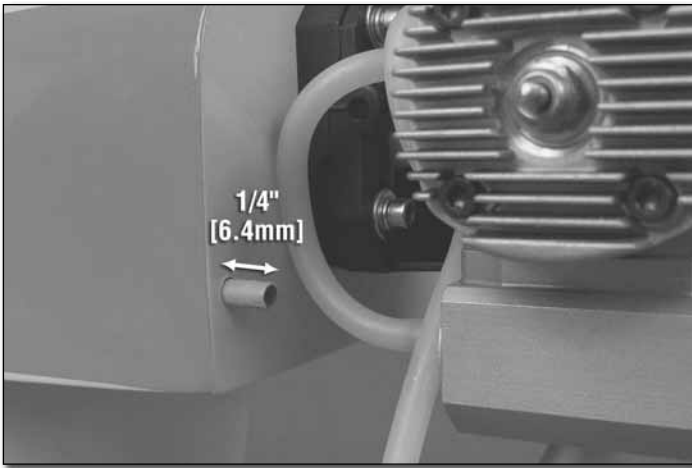

❑ 16. Roughen the ends of the 7-1/2" [191mm] outer pushrod tube using 220-grit sandpaper. Slide the outer pushrod tube through the hole in the firewall leaving 1/4" [6.4mm] protruding from the front of the firewall. Glue the outer pushrod tube to the firewall.

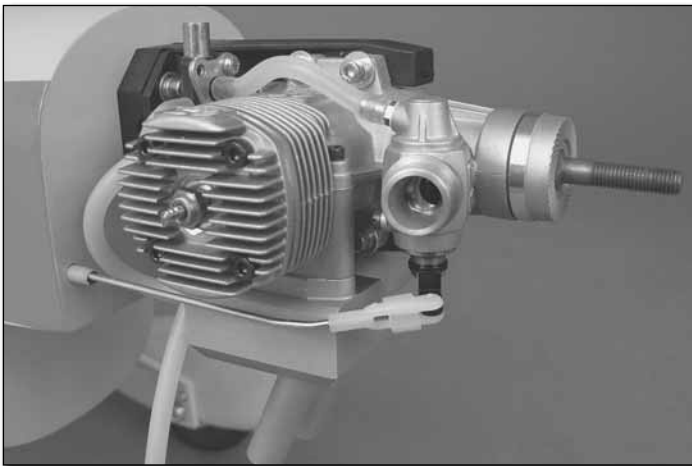
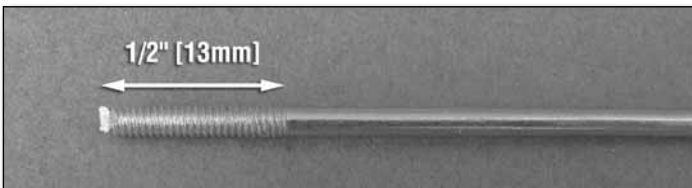

❑ 17. Cut part of the threads away leaving 1/2" [13mm] of thread length from the remaining 17-1/2" [445mm] pushrod. Thread a clevis and silicone clevis retainer onto the pushrod

and test fit into the outer pushrod tube. Make the necessary bends to the pushrod in order to clear the muffler. When satisfied, connect the clevis to the throttle arm on the engine and insert the aft end of the pushrod through the screw-lock pushrod connector. Make any necessary adjustments to the brass screw-lock connector so that the throttle opens and closes with the servo. Tighten the SHCS in the pushrod connector, cut away the excess pushrod 1/4" [6.4mm] behind the pushrod connector, and glue a plywood outer pushrod clip to the outer pushrod tube and fuel tank brace. Use the radio system to test the operation of the throttle, making sure it properly opens and closes.

### Brushless Motor Installation

*The Shoestring .46 ARF is designed to be flown with a .46-.55 two-stroke glow engine, .70-.81 four-stroke glow engine, or a brushless outrunner motor. If you plan to install a glow engine, skip this section as it only contains information relevant to installing a brushless motor.*

**Be sure to read and understand the instructions that come with the ESC and motor before attempting to operate the system.**

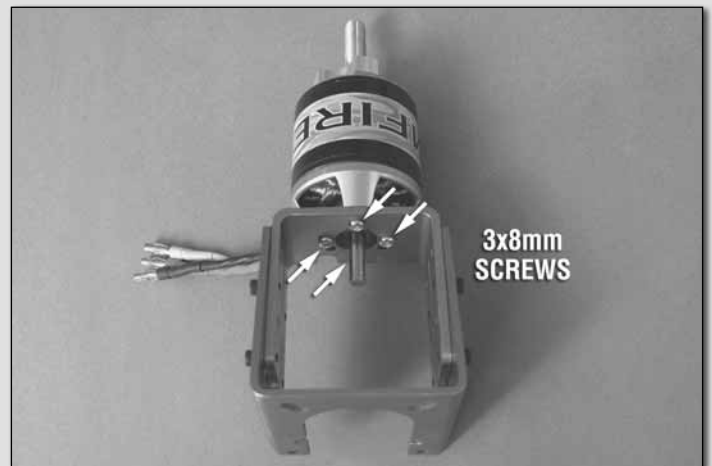

❑ 1. Attach the outrunner motor to the brushless motor mount using the included 3 x 8mm machine screws and thread locking compound. If you haven't done so yet, install the prop adapter to the motor case with the hardware included with the motor and thread locking compound.

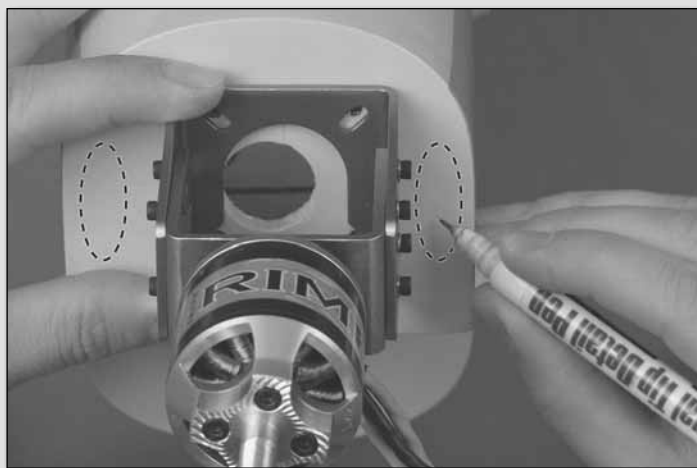

2. Temporarily attach the motor mount to the firewall with two 6-32 x 3/4" [19mm] SHCS or hold the motor mount in position while you mark the location for cooling holes in the location shown. There should be an elliptical-shaped hole on both sides of the mount. Use a rotary tool to cut out the holes before attaching the mount. When satisfied with the size and shape of the holes, attach the motor mount to the firewall using four 6-32 x 3/4" [19mm] SHCS, four #6 flat washers, four #6 lock washers, and thread locking compound.

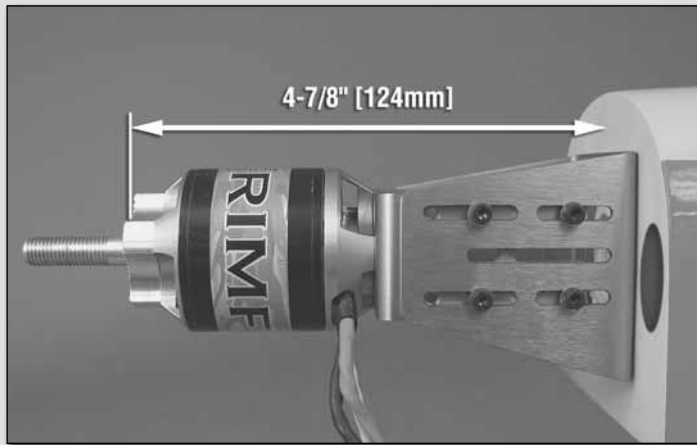

3. Loosen the screws that hold the aluminum motor mount halves together and slide them apart as necessary so that the front of the prop adapter is 4-7/8" [124mm] from the firewall. When adjusting the mount, do not inadvertently create an up or down motor thrust angle. Use thread locking compound on the screws that join the motor mount halves.

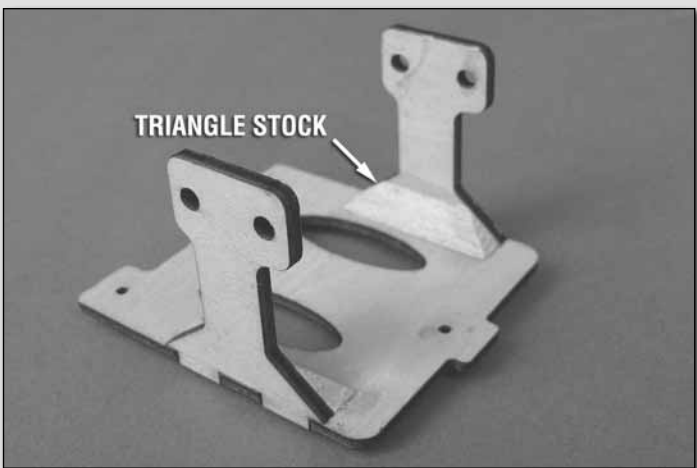

4. Assemble the ESC tray as shown. Use pieces from the included 6x6mm triangle stock to reinforce the tray sides.

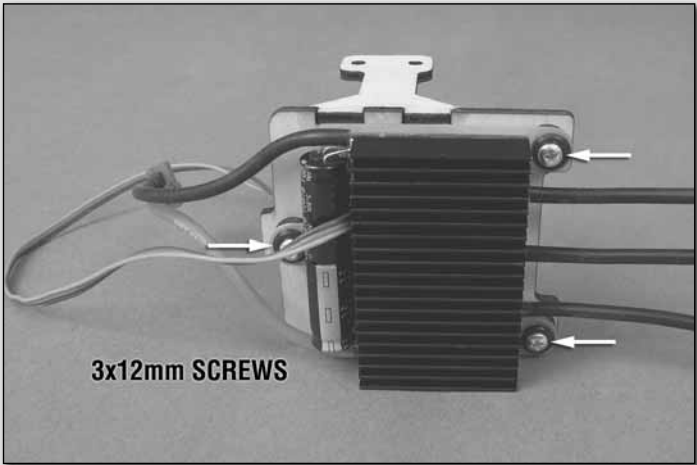

5. Attach the ESC to the tray using three 3x12mm self-tapping screws. Be sure to harden the screw holes with thin CA. Other brand ESCs may need to be attached to the tray with tie straps (not included) or a hook and loop strap.

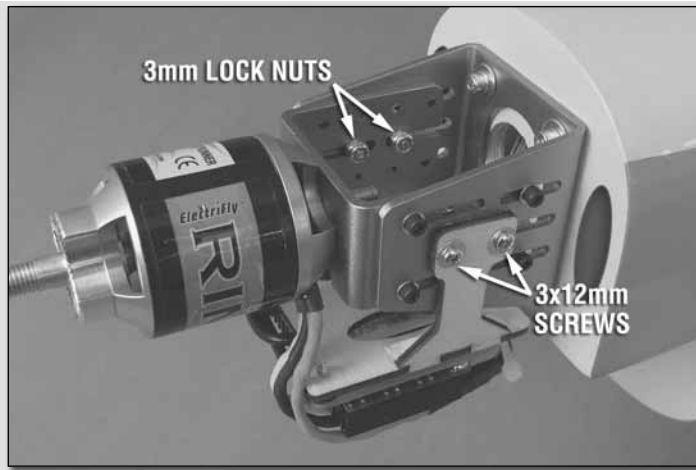

❑ 6. If you are using the recommended Great Planes SS-80 ESC, you will need to attach a 6" [152mm] servo extension. Secure the extension with tape, heat shrink tubing, or a special clip designed for that purpose. Attach the ESC tray to the brushless motor mount using four 3x12mm machine screws, four 3mm flat washers, and four 3mm nylon lock nuts. The battery and ESC receiver leads should be routed through the center hole in the firewall. Secure the excess motor leads out of the way of the motor. We used a tie strap (not included).

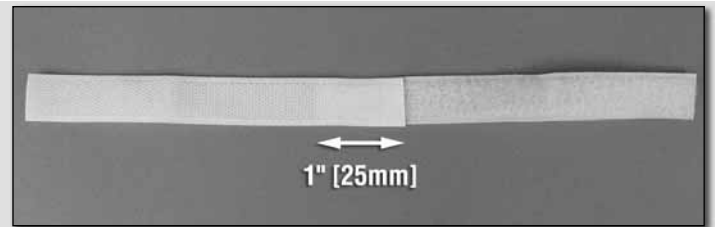

❑ 8. Make a strap from the included non-adhesive hook and loop material long enough to fit your battery packs. Feed the strap through the slots in the battery.



❑ 9. Test fit your batteries onto the tray. The exact position of the batteries will be determined when you will check the balance of the plane after the assembly has been completed. When you confirm the needed position of the batteries on the tray, mark that position somewhere on the tray. Now would also be a good time to confirm the correct rotation of the motor (before you install the propeller) using your radio system. The motor should rotate counter-clockwise when looking at the airplane from the front. If the motor rotates in the wrong direction, simply disconnect any two of the three motor leads and swap their positions.

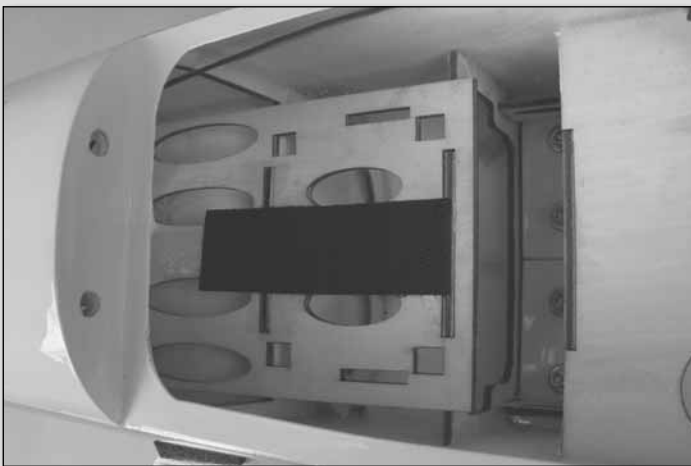

❑ 7. Apply a thin coat of epoxy down the center of the battery tray. This will improve the adhesion of the hook and loop material. When the epoxy has completely cured, attach a piece of the hook side from the included hook and loop strap to the battery tray. The loop side should be attached to your battery pack (use additional pieces to join LiPo packs together for a series configuration).

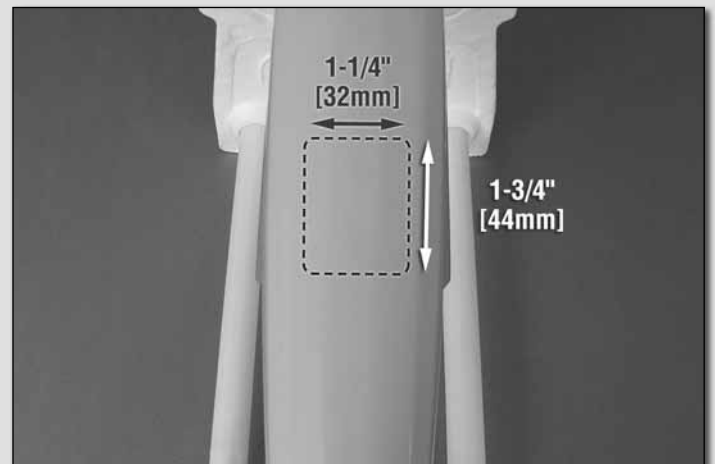

❑ 10. A cool air exit hole needs to be cut into the underside of the fuse behind the wing. A rotary tool with a cutting bit works well for this. Be sure your hole is made **between** the formers, not through them.

## FINISH THE MODEL

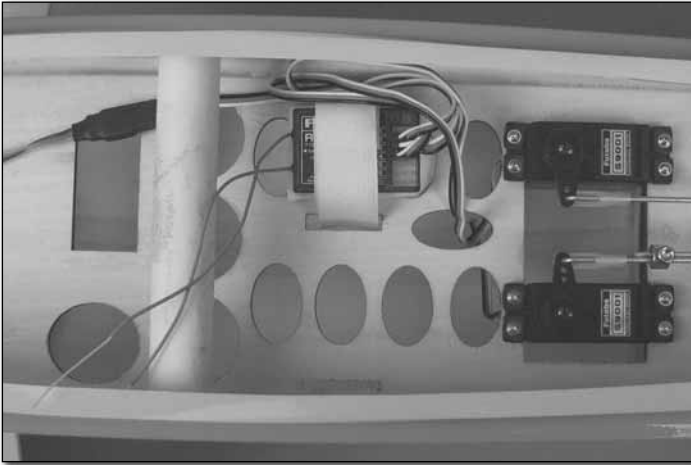

❑ 1. Make a strap from the included hook and loop material to fit your receiver. Cut a piece of foam rubber (not included) to fit your receiver and strap the receiver to the tray in front of the tail servos as shown. Connect the rudder and elevator servos to the receiver (and ESC if applicable).

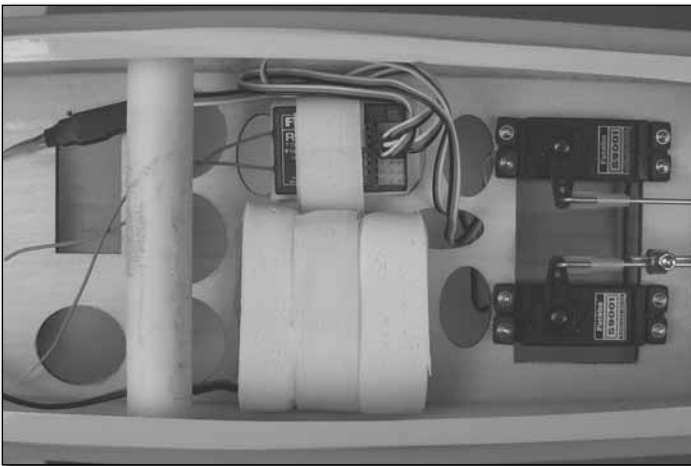

❑ 2. Mount the receiver battery pack next to the receiver in the same manner.



❑ 3. Mount your switch harness to the fuselage side in the location that you prefer. We mounted ours below the wing near the leading edge. If your muffler outlet is on the side of

the plane, be sure to mount the switch on the opposite side. Connect the switch to the battery and receiver, being sure to secure the connection between switch and battery. You can also install a charge jack receptacle. However, we chose to leave this out since the Shoestring has a magnetically attached canopy hatch. Just be sure to keep the charge jack lead in an accessible location in the fuse.



❑ 4. With everything connected, we suggest bundling the excess wires and use a tie strap to keep them out of the way of the hatch opening and tail servos.

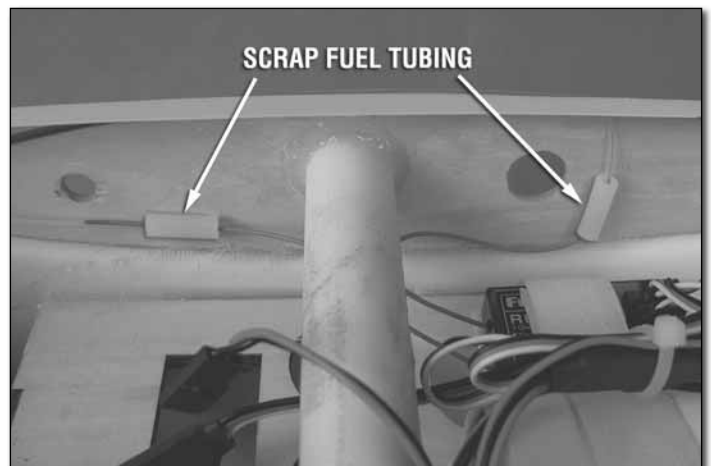

❑ 5. We used some scrap pieces of fuel tubing to support the dual receiver antennas in the correct orientation against the inside of the fuse (see your radio manual for details). If you have installed an FM or PCM receiver, route your receiver antenna through the antenna tube and out the aft end of the fuse. Be sure to install a strain relief on the antenna (if applicable).

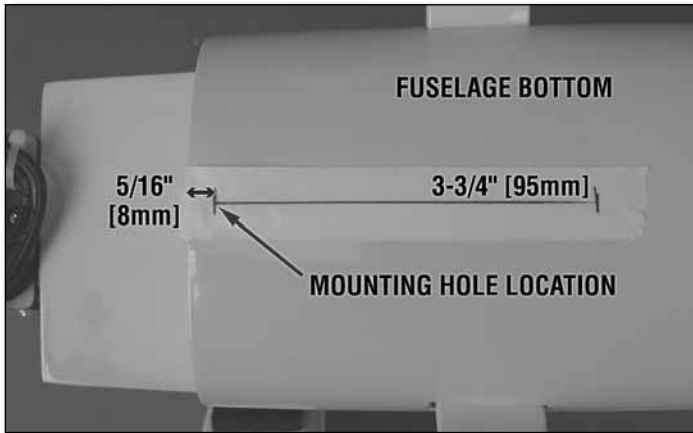
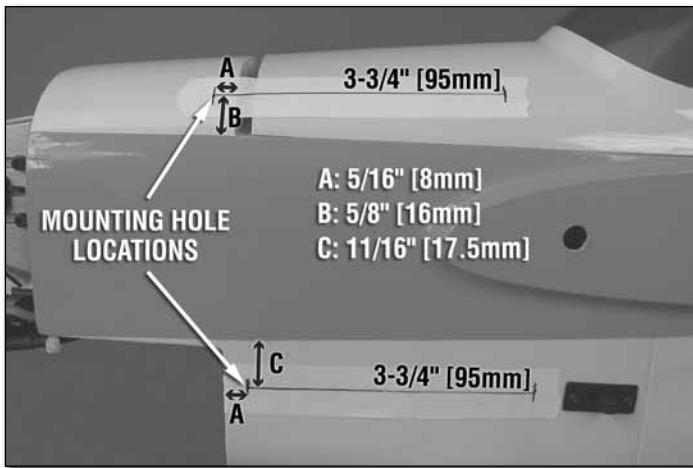

❑ 6. Install the canopy hatch onto the fuselage by fitting the dowels into the receiving holes, pressing the tabs at the aft end of the hatch into the slots, and then sliding the hatch back. Apply pieces of masking tape in the locations shown. Mark the locations for the cowl mounting screw holes on the tape using the measurements shown in the pictures. In order to transfer the mounting hole locations onto the cowl, draw a 3-3/4" [95mm] line along the tape pieces, starting the lines at your marks.

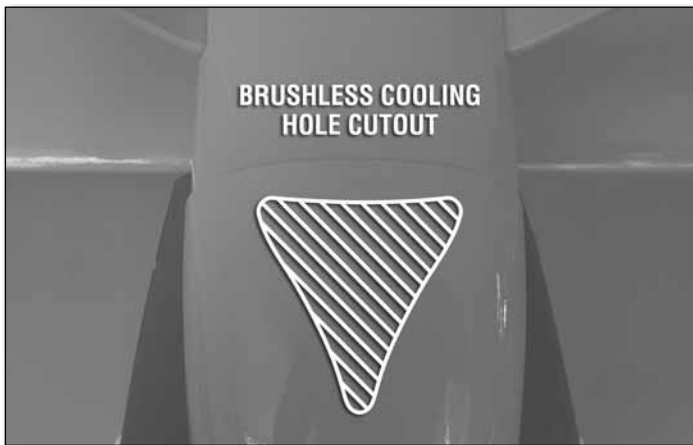

❑ 7. Before fitting the cowl, make any cutouts necessary for your power system. If you are installing a glow engine, a cutout must be made for the engine head, exhaust outlets, clearance for the throttle clevis, and needle valve access. A 1/4" [6.4mm] hole can be drilled or reamed into the cowl for convenient fill line access. The fuel tubing will slide through the hole, but the included fuel line plug will fit snugly into the

hole, holding it securely in place during flight. If you have installed a brushless power system, make a cooling hole cutout near the bottom aft edge of the cowl. Templates for cooling hole cutouts are provided in the back of this manual if you have installed a brushless system.

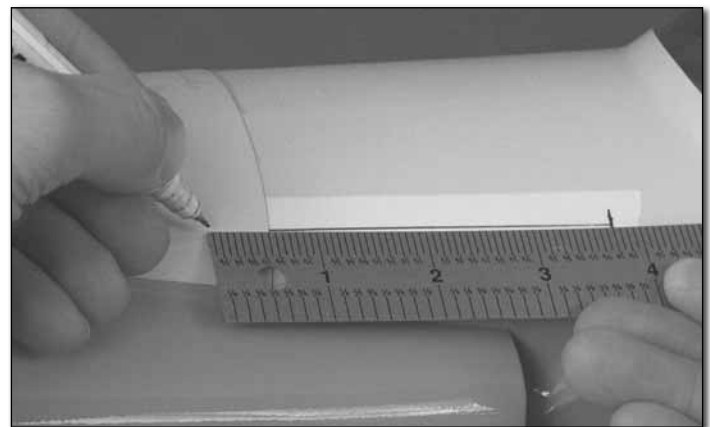
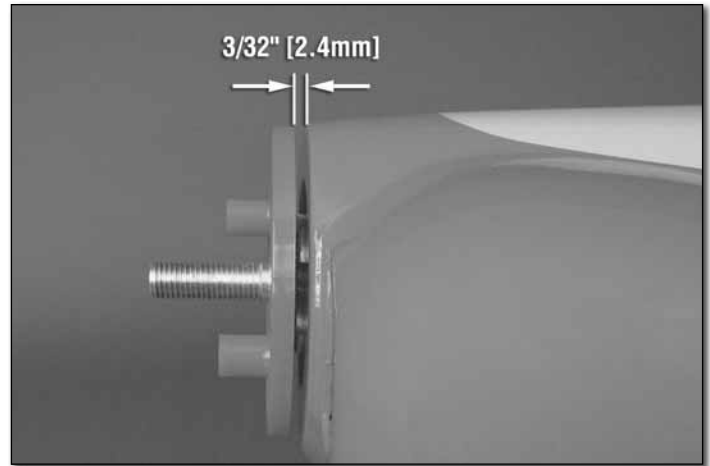

❑ 8. If necessary, ream the spinner backplate to match the diameter of the prop shaft. Fit the cowl onto the fuselage and slide the spinner backplate onto the prop shaft. Position the cowl so that the front of it is centered with the spinner backplate and is 3/32" [2.4mm] behind it. Temporarily tape the cowl into place or have a helper hold it steady while you transfer the cowl mounting hole locations onto the cowl. Do this by measuring forward along the lines on the tape 3-3/4" [95mm] and marking on the cowl for the five screw holes.

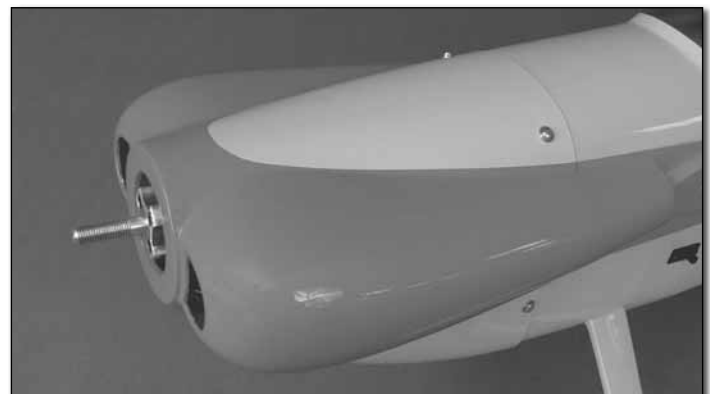

❑ 9. Drill 5/64" [2mm] holes at the marks you made on the cowl **through the cowl mounting blocks** that are pre-glued inside the fuselage. Remove the cowl and thread a #4 x 1/2"

[13mm] self-tapping screw into each hole in the fuselage and back it out. Apply a couple drops of thin CA to each hole in the blocks. Enlarge the five holes in the cowl with a 1/8" [3.2mm] bit. Install the cowl onto the fuselage using five #4 x 1/2" [13mm] self-tapping screws and five #4 flat washers.

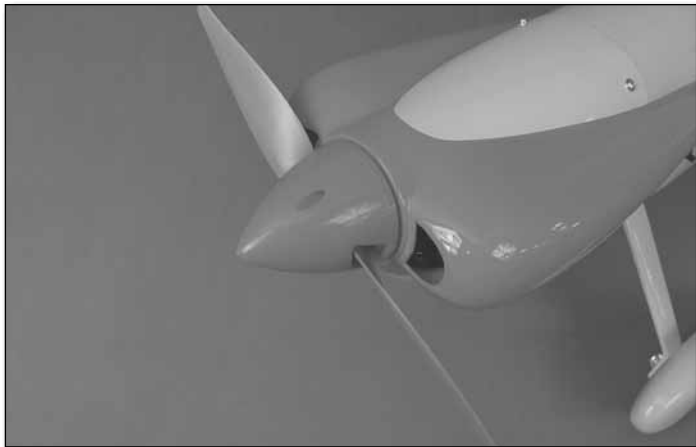

❑ 10. Install the spinner backplate, propeller, prop washer, and prop nut onto the motor. Install the spinner cone using the screws included inside the spinner package.

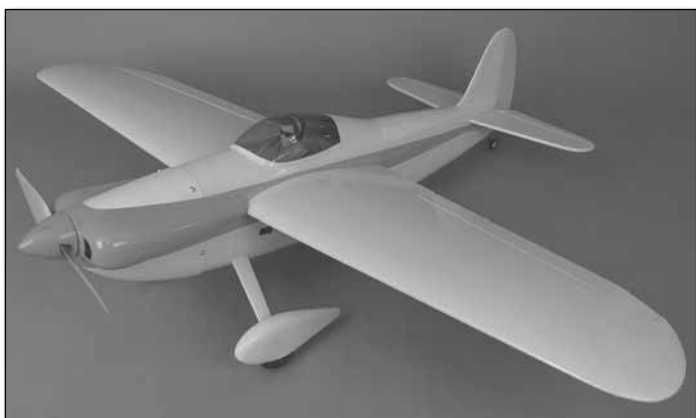

You have now completed the assembly!

## APPLY THE DECALS

1. Use scissors or a sharp hobby knife to cut the decals from the sheet.
2. Be certain the model is clean and free from oily fingerprints and dust. Prepare a dishpan or small bucket with a mixture of liquid dish soap and warm water—about one teaspoon of soap per gallon of water. Submerge the decal in the soap and water and peel off the paper backing. **Note:** Even though the decals have a “sticky-back” and are not the water transfer type, submersing them in soap and water allows accurate positioning and reduces air bubbles underneath.
3. Position decal on the model where desired. Holding the decal down, use a paper towel to wipe most of the water away.
4. Use a piece of soft balsa or something similar to squeegee remaining water from under the decal. Apply the rest of the decals the same way.

## GET THE MODEL READY TO FLY

### Install and Operate the Motor Battery (Brushless Only)

**IMPORTANT:** If using multiple battery packs connected with an adapter, never charge the batteries together through the adapter. Always charge each battery pack separately. Charge the batteries, then read the following precautions on how to connect multiple packs for flying the model:

#### BATTERY PRECAUTIONS:

There are two ways to connect multiple battery packs: In **Series** and in **Parallel**.

These are two 3200mAh batteries (one 11.1V and the other 7.4V). When joined in **SERIES**, the result will be a 18.5V, 3200 mAh battery.

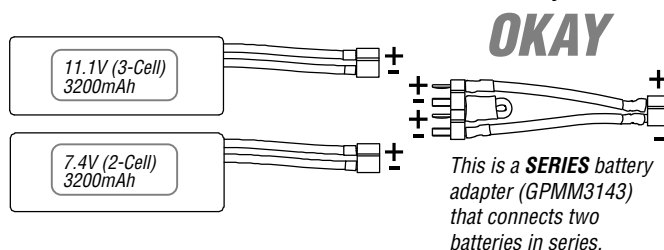

It's okay to connect batteries with different voltages in series to achieve the new, desired voltage.

Connecting batteries in “**Series**” means to connect the (+)'s to the (-)'s and the (-)'s to the (+)'s. This combines the voltages of the batteries, but the capacity remains the same.

These two 1500mAh batteries (both 11.1V) are being joined in **PARALLEL**. The result will be one 11.1V, 3000mAh battery.

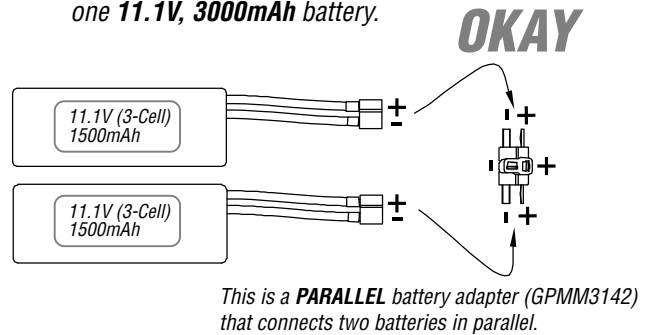

Connecting batteries in “**Parallel**” means to connect the (+)'s to the (+)'s and the (-)'s to the (-)'s. This combines the capacities of the batteries, but the voltage remains the same.

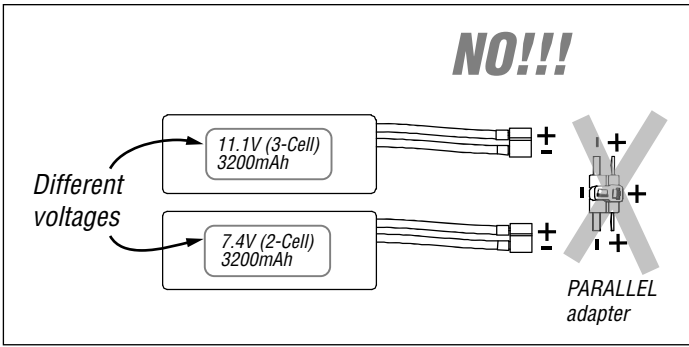

**NEVER** connect battery packs with different voltages in parallel! Only combine them in series. Otherwise, the batteries with lower voltage will try to “equalize” with the batteries that have a higher voltage. Current will flow from the higher voltage battery into the lower one, essentially “charging” the lower voltage battery pack. This situation will likely cause heat and possibly a fire.

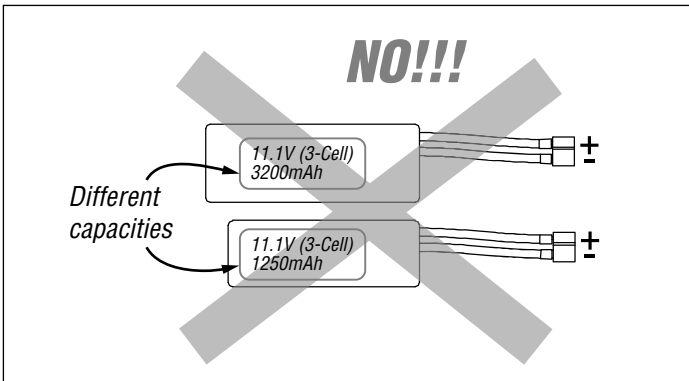

**NEVER** connect battery packs with different capacities in series or in parallel.

## Check the Control Directions

- ❑ 1. Turn on the transmitter and receiver and center the trims. If necessary, remove the servo arms from the servos and reposition them so they are centered. Reinstall the screws that hold on the servo arms.
- ❑ 2. With the transmitter and receiver still on, check all the control surfaces to see if they are centered. If necessary, adjust the clevises on the pushrods to center the control surfaces.

## 4-CHANNEL RADIO SET UP (STANDARD MODE 2)

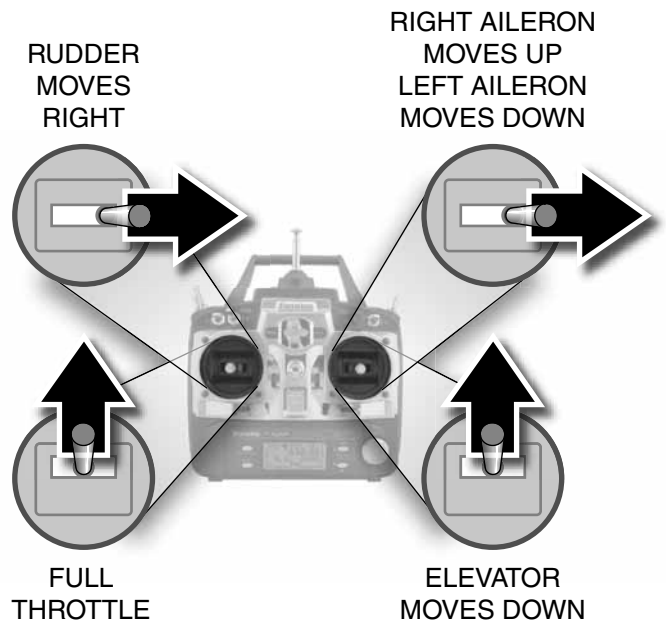

- ❑ 3. Make certain that the control surfaces and the carburetor respond in the correct direction as shown in the diagram. If any of the controls respond in the wrong direction, use the servo reversing in the transmitter to reverse the servos connected to those controls. Be certain the control surfaces have remained centered. Adjust if necessary.



## Set the Control Throws

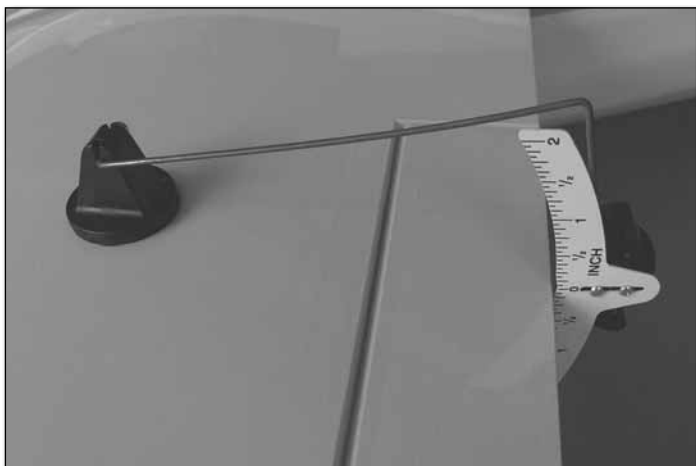

Use a Great Planes AccuThrow (or a ruler) to accurately measure and set the control throw of each control surface as indicated in the chart that follows. If your radio does not have dual rates, we recommend setting the throws at the **low** rate setting. **NOTE:** The throws are measured at the **widest part** of the elevators, rudder and ailerons.

### These are the recommended control surface throws:

	HIGH RATE		LOW RATE	
	Up	Down	Up	Down
<b>ELEVATOR</b>	1/2" [13mm]	1/2" [13mm]	3/8" [10mm]	3/8" [10mm]
	14°	14°	10°	10°
<b>RUDDER</b>	Right	Left	Right	Left
	7/8" [22mm]	7/8" [22mm]	5/8" [16mm]	5/8" [16mm]
<b>AILERONS</b>	Up	Down	Up	Down
	5/8" [16mm]	5/8" [16mm]	5/16" [8mm]	5/16" [8mm]
	17°	17°	8°	8°

**Exponential:** 40% exponential is recommended on aileron high rates. If your radio system does not have an exponential function, we suggest using low rate ailerons for your first few flights.

**IMPORTANT:** The Shoestring .46 ARF has been **extensively** flown and tested to arrive at the throws at which it flies best. Flying your model at these throws will provide you with the greatest chance for successful first flights. If, after you have become accustomed to the way the Shoestring flies, you would like to change the throws to suit your taste, that is fine. However, too much control throw could make the model difficult to control, so remember, “more is not always better.”

## Balance the Model (C.G.)

More than any other factor, the **C.G.** (balance point) can have the **greatest** effect on how a model flies, and may determine whether or not your first flight will be successful. If you value this model and wish to enjoy it for many flights, **DO NOT OVERLOOK THIS IMPORTANT PROCEDURE.** A model that is not properly balanced will be unstable and possibly unflyable.

At this stage the model should be in ready-to-fly condition with all of the systems in place including the engine or brushless motor, landing gear, and the radio system (and battery pack if applicable).

1. Use a felt-tip pen or 1/8" [3mm]-wide tape to accurately mark the C.G. on the bottom of the wing on both sides of the fuselage. **The C.G. is located 3-5/8" [92mm] back from the leading edge of the wing.**

This is where your model should balance for the first flights. Later, you may wish to experiment by shifting the C.G. up to 3/8" [10mm] forward or 3/8" [10mm] back to change the flying characteristics. Moving the C.G. forward may improve the smoothness and stability, but the model may then require more speed for takeoff and make it more difficult to slow for landing. Moving the C.G. aft makes the model more maneuverable, but could also cause it to become too difficult to control. In any case, **start at the recommended balance point** and do not at any time balance the model outside the specified range.

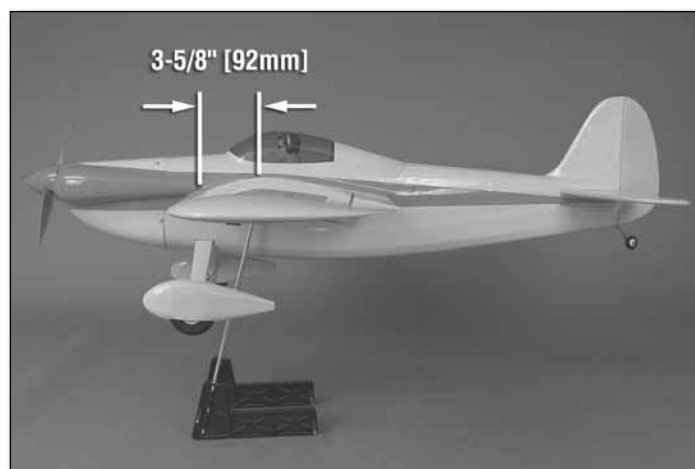

2. With the wing attached to the fuselage, all parts of the model installed (ready to fly) and an empty fuel tank, place the model on a Great Planes CG Machine, or lift it upside-down at the balance point you marked.

3. If the tail drops, the model is “tail heavy” and the battery pack and/or receiver must be shifted forward or weight must be added to the nose to balance. If the nose drops, the model is “nose heavy” and the battery pack and/or receiver must be shifted aft or weight must be added to the tail to balance. If possible, relocate the battery pack and receiver

to minimize or eliminate any additional ballast required. If additional weight is required, nose weight may be easily added by using a “spinner weight” (GPMQ4645 for the 1 oz. [28g] weight, or GPMQ4646 for the 2 oz. [57g] weight). If spinner weight is not practical or is not enough, use Great Planes (GPMQ4485) “stick-on” lead. A good place to add stick-on nose weight is to the firewall (don’t attach weight to the cowl—it is not intended to support weight). Begin by placing incrementally increasing amounts of weight on the bottom of the fuse over the firewall until the model balances. Once you have determined the amount of weight required, it can be permanently attached. If required, tail weight may be added by cutting open the bottom of the fuse and gluing it permanently inside.

**Note:** Do not rely upon the adhesive on the back of the lead weight to permanently hold it in place. Over time, fuel and exhaust residue may soften the adhesive and cause the weight to fall off. Use #2 sheet metal screws, RTV silicone or epoxy to permanently hold the weight in place.

**4. IMPORTANT:** If you found it necessary to add any weight, recheck the C.G. after the weight has been installed.

### ***Balance the Model Laterally***

1. With the wing level, have an assistant help you lift the model by the engine propeller shaft and the bottom of the fuse under the TE of the fin. Do this several times.

2. If one wing always drops when you lift the model, it means that side is heavy. Balance the airplane by adding weight to the other wing tip. **An airplane that has been laterally balanced will track better in loops and other maneuvers.**

## ***PREFLIGHT***

### ***Identify Your Model***

No matter if you fly at an AMA sanctioned R/C club site or if you fly somewhere on your own, you should always have your name, address, telephone number and AMA number on or inside your model. It is **required** at all AMA R/C club flying sites and AMA sanctioned flying events. Fill out the identification tag on page 31 (or on the decal sheet) and place it on or inside your model.

### ***Charge the Batteries***

Follow the battery charging instructions that came with your radio control system to charge the batteries. You should always charge your transmitter and receiver batteries the night before you go flying, and at other times as recommended by the radio manufacturer.

**CAUTION:** Unless the instructions that came with your radio system state differently, the **initial** charge on **new** transmitter and receiver batteries should be done for 15 hours **using the slow-charger that came with the radio system**. This will “condition” the batteries so that the next charge may be done using the fast-charger of your choice. If the initial charge is done with a fast-charger the batteries may not reach their full capacity and you may be flying with batteries that are only partially charged.

### ***Balance Propellers***

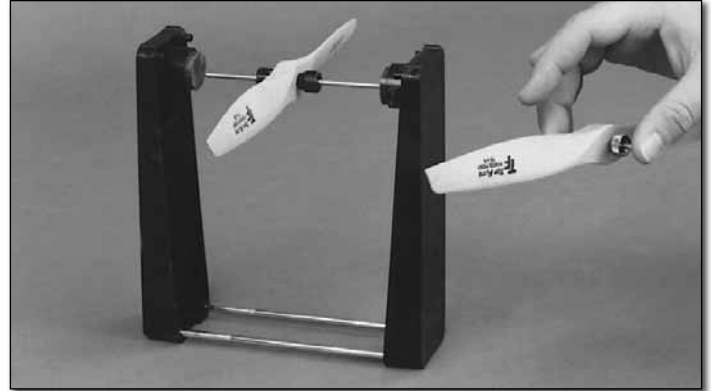

Carefully balance your propeller and spare propellers before you fly. An unbalanced prop can be the single most significant cause of vibration that can damage your model. Not only will engine mounting screws and bolts loosen, possibly with disastrous effect, but vibration may also damage your radio receiver and battery. Vibration can also cause your fuel to foam, which will, in turn, cause your engine to run hot or quit.

We use a Top Flite Precision Magnetic Prop Balancer (TOPQ5700) in the workshop and keep a Great Planes Fingertip Prop Balancer (GPMQ5000) in our flight box.

### ***Ground Check***

**If the engine is new, follow the engine manufacturer’s instructions to break-in the engine.** After break-in, confirm that the engine idles reliably, transitions smoothly and rapidly to full power and maintains full power—indefinitely. After you run the engine on the model, inspect the model closely to make sure all screws remained tight, the hinges are secure, the prop is secure and all pushrods and connectors are secure.

### ***Range Check***

Ground check the operational range of your radio before the first flight of the day. With the transmitter antenna collapsed and the receiver and transmitter on, you should be able to walk at least 100 feet away from the model and still have control (if using a 2.4GHz radio system, refer to the radio manual for the range checking procedure). Have an assistant stand by your model and, while you work the

controls, tell you what the control surfaces are doing. Repeat this test **with the engine running** at various speeds with an assistant holding the model, using hand signals to show you what is happening. If the control surfaces do not respond correctly, **do not fly!** Find and correct the problem first. Look for loose servo connections or broken wires, corroded wires on old servo connectors, poor solder joints in your battery pack or a defective cell, or a damaged receiver crystal from a previous crash.

## ENGINE SAFETY PRECAUTIONS

**Failure to follow these safety precautions may result in severe injury to yourself and others.**

- Keep all engine fuel in a safe place, away from high heat, sparks or flames, as fuel is very flammable. Do not smoke near the engine or fuel; and remember that engine exhaust gives off a great deal of deadly carbon monoxide. Therefore **do not run the engine in a closed room or garage.**
- Get help from an experienced pilot when learning to operate engines.
- Use safety glasses when starting or running engines.
- Do not run the engine in an area of loose gravel or sand; the propeller may throw such material in your face or eyes.
- Keep your face and body as well as all spectators away from the plane of rotation of the propeller as you start and run the engine.
- Keep these items away from the prop: loose clothing, shirt sleeves, ties, scarves, long hair or loose objects such as pencils or screwdrivers that may fall out of shirt or jacket pockets into the prop.
- Use a “chicken stick” or electric starter to start the engine. Do not use your fingers to flip the propeller. Make certain the glow plug clip or connector is secure so that it will not pop off or otherwise get into the running propeller.
- Make all engine adjustments from behind the rotating propeller.
- The engine gets hot! Do not touch it during or right after operation. Make sure fuel lines are in good condition so fuel will not leak onto a hot engine, causing a fire.
- To stop a glow engine, cut off the fuel supply by closing off the fuel line or following the engine manufacturer's recommendations. Do not use hands, fingers or any other body part to try to stop the engine. To stop a gasoline powered engine an on/off switch should be connected to the engine coil. Do not throw anything into the propeller of a running engine.

## LITHIUM BATTERY HANDLING AND USAGE

**WARNING!!** Read the entire instruction sheet included with your battery. Failure to follow all instructions could cause permanent damage to the battery and its surroundings, and cause bodily harm!

- ONLY use a Li-Po approved charger. NEVER use a NiCd/ NiMH peak charger!
- NEVER charge in excess of 4.20V per cell.
- ONLY charge through the “charge” lead. NEVER charge through the “discharge” lead.
- NEVER charge at currents greater than 1C.
- ALWAYS set charger's output volts to match battery volts.
- ALWAYS charge in a fireproof location.
- NEVER trickle charge.
- NEVER allow the battery temperature to exceed 150° F (65° C).
- NEVER disassemble or modify pack wiring in any way or puncture cells.
- NEVER discharge below 2.5V per cell.
- NEVER place on combustible materials or leave unattended during charge or discharge.
- ALWAYS KEEP OUT OF REACH OF CHILDREN.

## AMA SAFETY CODE (EXCERPTS)

Read and abide by the following excerpts from the Academy of Model Aeronautics Safety Code. For the complete Safety Code refer to *Model Aviation* magazine, the AMA web site or the Code that came with your AMA license.

### General

- 1) I will not fly my model aircraft in sanctioned events, air shows, or model flying demonstrations until it has been proven to be airworthy by having been previously, successfully flight tested.
- 2) I will not fly my model aircraft higher than approximately 400 feet within 3 miles of an airport without notifying the airport operator. I will give right-of-way and avoid flying in the proximity of full-scale aircraft. Where necessary, an observer shall be utilized to supervise flying to avoid having models fly in the proximity of full-scale aircraft.
- 3) Where established, I will abide by the safety rules for the flying site I use, and I will not willfully and deliberately fly my models in a careless, reckless and/or dangerous manner.
- 5) I will not fly my model unless it is identified with my name and address or AMA number, on or in the model. Note: This does not apply to models while being flown indoors.
- 7) I will not operate models with pyrotechnics (any device that explodes, burns, or propels a projectile of any kind).

## Radio Control

- 1) I will have completed a successful radio equipment ground check before the first flight of a new or repaired model.
- 2) I will not fly my model aircraft in the presence of spectators until I become a qualified flier, unless assisted by an experienced helper.
- 3) At all flying sites a straight or curved line(s) must be established in front of which all flying takes place with the other side for spectators. Only personnel involved with flying the aircraft are allowed at or in the front of the flight line. Intentional flying behind the flight line is prohibited.
- 4) I will operate my model using only radio control frequencies currently allowed by the Federal Communications Commission.
- 5) **I will not knowingly operate my model within three miles of any pre-existing flying site except in accordance with the frequency sharing agreement listed** [in the complete AMA Safety Code].
- 9) Under no circumstances may a pilot or other person touch a powered model in flight; **nor should any part of the model other than the landing gear, intentionally touch the ground, except while landing.**

## CHECK LIST

During the last few moments of preparation your mind may be elsewhere anticipating the excitement of the first flight. Because of this, you may be more likely to overlook certain checks and procedures that should be performed before the model is flown. To help avoid this, a check list is provided to make sure these important areas are not overlooked. Many are covered in the instruction manual, so where appropriate, refer to the manual for complete instructions. Be sure to check the items off as they are completed.

1. Check the C.G. according to the measurements provided in the manual.
2. Be certain the battery and receiver are securely mounted in the fuse. Simply stuffing them into place with foam rubber is not sufficient.
3. Extend your receiver antenna.
4. Balance your model *laterally* as explained in the instructions.
5. Use threadlocking compound to secure critical fasteners such as the set screws that hold the wheel axles to the struts, screws that hold the carburetor arm (if applicable), screw-lock pushrod connectors, etc.
6. Add a drop of oil to the axles so the wheels will turn freely.
7. Make sure all hinges are **securely** glued in place.
8. Reinforce holes for wood screws with thin CA where appropriate (servo mounting screws, cowl mounting screws, etc.).
9. Confirm that all controls operate in the correct direction and the throws are set up according to the manual.

10. Make sure there are silicone retainers on all the clevises and that all servo arms are secured to the servos with the screws included with your radio.
11. Secure connections between servo wires and Y-connectors or servo extensions, and the connection between your battery pack and the on/off switch with vinyl tape, heat shrink tubing or special clips suitable for that purpose.
12. Make sure any servo extension cords you may have used do not interfere with other systems (servo arms, pushrods, etc.).
13. Secure the pressure tap (if used) to the muffler with high temp RTV silicone, thread locking compound or J.B. Weld.
14. Make sure the fuel lines are connected and are not kinked.
15. Balance your propeller (and spare propellers).
16. Tighten the propeller nut and spinner.
17. Place your name, address, AMA number and telephone number on or inside your model.
18. Cycle your receiver battery pack (if necessary) and make sure it is fully charged.
19. If you wish to photograph your model, do so before your first flight.
20. Range check your radio when you get to the flying field.

## FLYING

The Shoestring .46 ARF is a great-flying model that flies smoothly and predictably. The Shoestring does not, however, possess the self-recovery characteristics of a primary R/C trainer and should be flown only by experienced R/C pilots.

### CAUTION (THIS APPLIES TO ALL R/C AIRPLANES):

If, while flying, you notice an alarming or unusual sound such as a low-pitched "buzz," this may indicate control surface *flutter*. Flutter occurs when a control surface (such as an aileron or elevator) or a flying surface (such as a wing or stab) rapidly vibrates up and down (thus causing the noise). In extreme cases, if not detected immediately, flutter can actually cause the control surface to detach or the flying surface to fail, thus causing loss of control followed by an impending crash. The best thing to do when flutter is detected is to slow the model **immediately** by reducing power, then land as soon as safely possible. Identify which surface fluttered (so the problem may be resolved) by checking all the servo grommets for deterioration or signs of vibration. Make certain all pushrod linkages are secure and free of play. If it fluttered once, under similar circumstances it will probably flutter again unless the problem is fixed. Some things which can cause flutter are; Excessive hinge gap; Not mounting control horns solidly; Poor fit of clevis pin in horn; Side-play of wire pushrods caused by large bends; Excessive free play in servo gears; Insecure servo mounting; and one of the most prevalent causes of flutter; Flying an over-powered model at excessive speeds.

## Fuel Mixture Adjustments

A fully cowled engine may run at a higher temperature than an un-cowled engine. For this reason, the fuel mixture should be richened so the engine runs at about 200 rpm below peak speed. By running the engine slightly rich, you will help prevent dead-stick landings caused by overheating.

## Takeoff

Before you get ready to takeoff, see how the model handles on the ground by doing a few practice runs at **low speeds** on the runway. Hold “up” elevator to keep the tail wheel on the ground. If necessary, adjust the tail wheel so the model will roll straight down the runway. If you need to calm your nerves before the maiden flight, shut the engine down and bring the model back into the pits. Top off the fuel, then check all fasteners and control linkages for peace of mind.

Remember to takeoff into the wind. When you're ready, point the model straight down the runway, hold a bit of up elevator to keep the tail on the ground to maintain tail wheel steering, then gradually advance the throttle. As the model gains speed decrease up elevator, allowing the tail to come off the ground. One of the most important things to remember with a tail dragger is to always be ready to apply **right** rudder to counteract engine torque. Gain as much speed as your runway and flying site will practically allow before gently applying up elevator, lifting the model into the air. At this moment it is likely that you will need to apply more right rudder to counteract engine torque. Be smooth on the elevator stick, allowing the model to establish a **gentle** climb to a safe altitude before turning into the traffic pattern.

## Flight

For reassurance and to keep an eye on other traffic, it is a good idea to have an assistant on the flight line with you. Tell him to remind you to throttle back once the plane gets to a comfortable altitude. While full throttle is usually desirable for takeoff, most models fly more smoothly at reduced speeds.

Take it easy with the Shoestring for the first few flights, gradually getting acquainted with it as you gain confidence. Adjust the trims to maintain straight and level flight. If you have powered the airplane with a .46 engine, you will find the plane fast, but not so fast to get yourself in trouble. If you have powered it with a .55 engine, the airplane becomes very fast so be sure to get fully acquainted with how it performs before attempting complex maneuvers that could get you into trouble. After flying around for a while and while still at a safe altitude with plenty of fuel, practice slow flight and execute practice landing approaches by reducing the throttle to see how the model handles at slower speeds. Add power to see how the model climbs as well. Continue to fly around, executing various maneuvers and making mental notes (or

having your assistant write them down) of what trim or C.G. changes may be required to fine tune the model so it flies the way you like. Mind your fuel level, but use this first flight to become familiar with your model before landing.

## Landing

The Shoestring has a clean, racing airframe. Because of this, you will find that it takes longer to slow the plane for landing than some other airplanes you have flown. Be prepared for this and don't be surprised if you have to go around and set up for your landing a second time. To initiate a landing approach, lower the throttle while on the downwind leg. Allow the nose of the model to pitch downward to gradually bleed off altitude. Continue to lose altitude, but maintain airspeed by keeping the nose down as you turn onto the crosswind leg. Make your final turn toward the runway (into the wind) keeping the nose down to maintain airspeed and control. Level the attitude when the model reaches the runway threshold, modulating the throttle as necessary to maintain your glide path and airspeed. If you are going to overshoot, smoothly advance the throttle (always ready on the right rudder to counteract torque) and climb out to make another attempt. When you're ready to make your landing flare and the model is a foot or so off the deck, smoothly increase up elevator until it gently touches down. Once the model is on the runway and has lost flying speed, hold up elevator to place the tail on the ground, regaining tail wheel control.

One final note about flying your model. Have a goal or flight plan in mind for **every** flight. This can be learning a new maneuver(s), improving a maneuver(s) you already know, or learning how the model behaves in certain conditions (such as on high or low rates). This is not necessarily to improve your skills (*though it is never a bad idea!*), but more importantly so you do not surprise yourself by impulsively attempting a maneuver and suddenly finding that you've run out of time, altitude or airspeed. Every maneuver should be deliberate, not impulsive. For example, if you're going to do a loop, check your altitude, mind the wind direction (anticipating rudder corrections that will be required to maintain heading), remember to throttle back at the top, and make certain you are on the desired rates (high/low rates). A flight plan greatly reduces the chances of crashing your model just because of poor planning and impulsive moves. **Remember to think.**

**Have a ball!**

**But always stay in control and fly in a safe manner.**

**GOOD LUCK AND GREAT FLYING!**

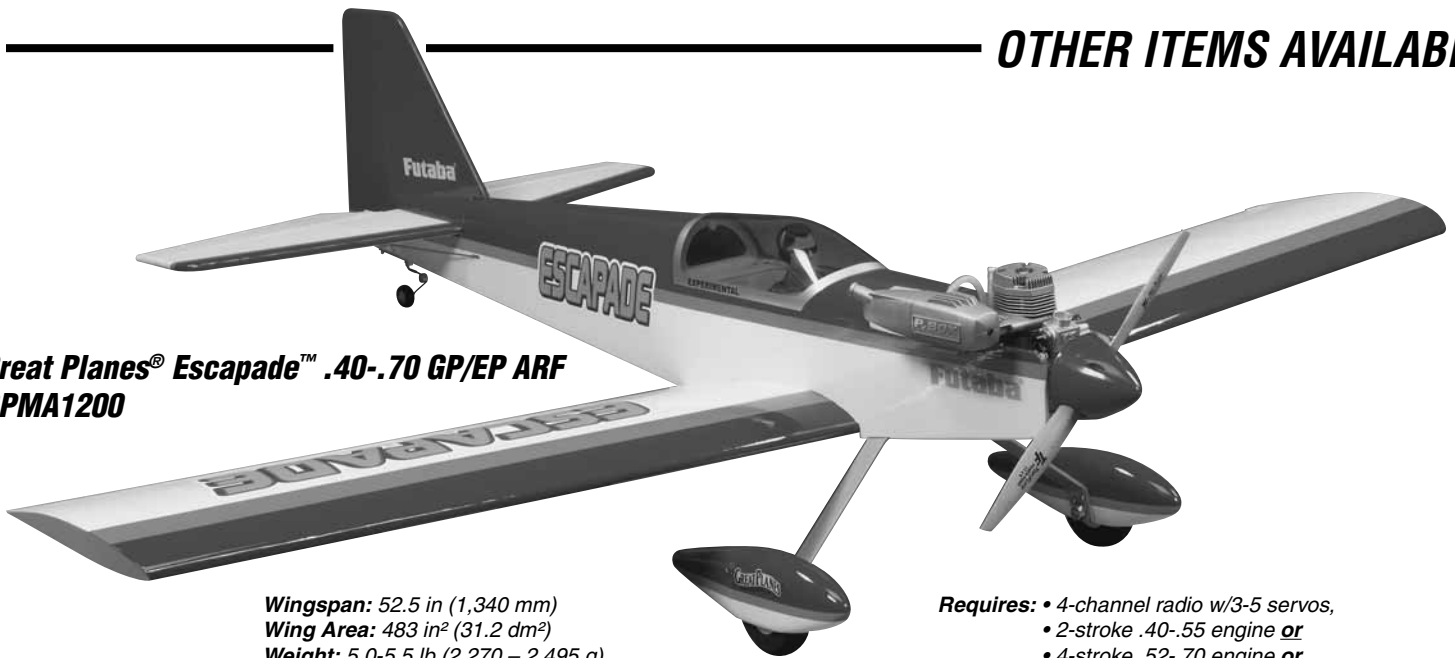
**Great Planes® Escapade™ .40-.70 GP/EP ARF  
GPMA1200**

**Wingspan:** 52.5 in (1,340 mm)  
**Wing Area:** 483 in<sup>2</sup> (31.2 dm<sup>2</sup>)  
**Weight:** 5.0-5.5 lb (2,270 – 2,495 g)  
**Wing Loading:** 24 - 26 oz/ft<sup>2</sup> (73 - 80 g/dm<sup>2</sup>)  
**Length:** 46 in (1,160 mm)

**Requires:** • 4-channel radio w/3-5 servos,  
• 2-stroke .40-.55 engine **or**  
• 4-stroke .52-.70 engine **or**  
• 800kV outrunner brushless motor,  
60A brushless ESC (min) &  
a 14.8V, 3200mAh LiPo battery pack

The Escapade is destined to become the plane you can't put down, the model that stands out as your all-time favorite. Easy handling and aerobatic performance are just two of the reasons you'll want to fly this ARF again and again. It flies great with either glow or electric power. With its built-up airframe, bolt-together construction, pre-hinged control surfaces and striking MonoKote® trim scheme already applied, assembling the Escapade requires just 4-6 hours. And ailerons can be set up for single-servo simplicity or dual-servo authority with no modification.

---

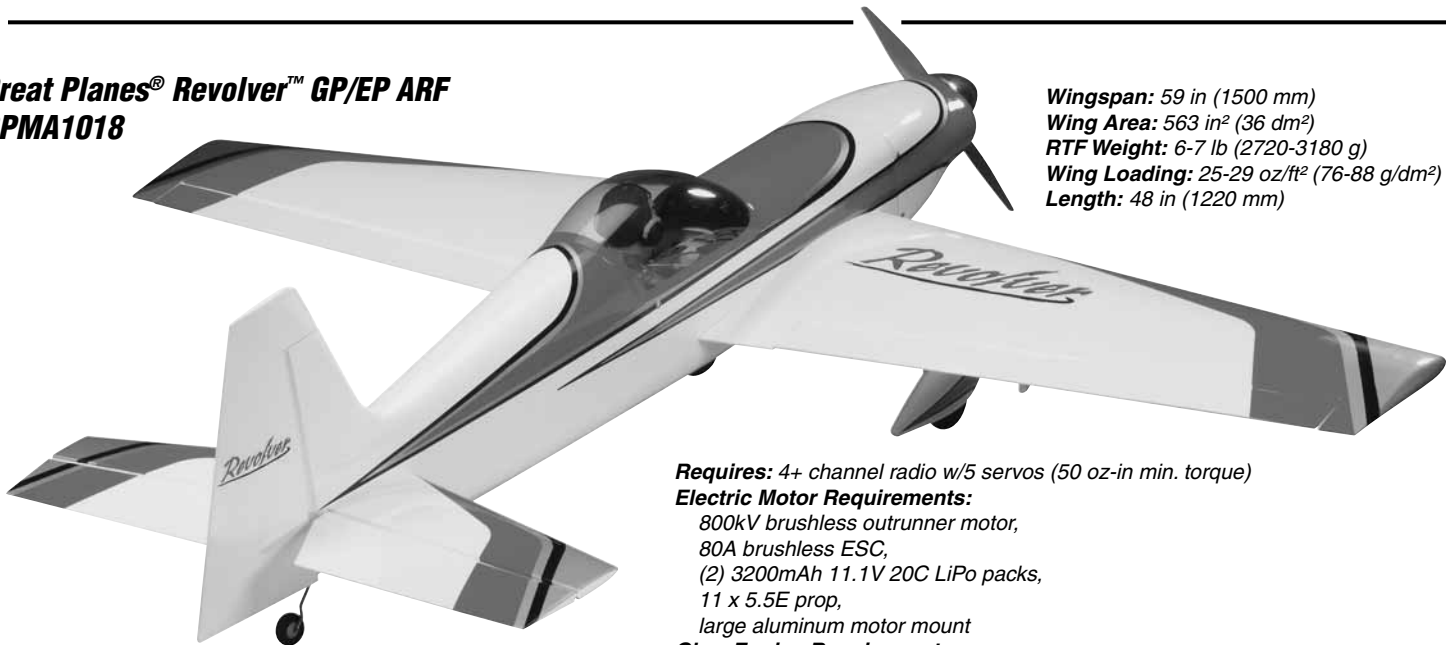
**Great Planes® Revolver™ GP/EP ARF  
GPMA1018**

**Wingspan:** 59 in (1500 mm)  
**Wing Area:** 563 in<sup>2</sup> (36 dm<sup>2</sup>)  
**RTF Weight:** 6-7 lb (2720-3180 g)  
**Wing Loading:** 25-29 oz/ft<sup>2</sup> (76-88 g/dm<sup>2</sup>)  
**Length:** 48 in (1220 mm)

**Requires:** 4+ channel radio w/5 servos (50 oz-in min. torque)

**Electric Motor Requirements:**

800kV brushless outrunner motor,  
80A brushless ESC,  
(2) 3200mAh 11.1V 20C LiPo packs,  
11 x 5.5E prop,  
large aluminum motor mount

**Glow Engine Requirements:**

2-stroke .46-.55 cu in (7.5-9.0 cc) **or**  
4-stroke .70 cu in (11.5 cc) engine

The 59" span Revolver looks fast, and its performance — under glow or brushless electric power — follows through with excellent high- and low-speed flight performance. Built from select balsa/ply, it features a 2-piece, balsa sheathed, foam core wing covered in MonoKote® film. The cowl, wheel pants and landing gear are light, painted fiberglass. But that's not even the best part. This fantastic sport aerobat only takes a mere 10 hours to assemble before it's flight-ready!

# FROM GREAT PLANES

## Great Planes® Reactor Biplane .61 GP/EP ARF GPMA1023



**Wingspan:** 48 in (1220 mm)  
**Wing Area:** 1145 in<sup>2</sup> (73.9 dm<sup>2</sup>)  
**Weight:** 7-7.5 lb (3170-3400 g)  
**Wing Loading:** 14-15 oz/ft<sup>2</sup> (43-46 g/dm<sup>2</sup>)  
**Length:** 58.5 in (1485 mm)

**Requires:**

- 4-5 channel radio w/7-8 servos
- 2-stroke .61 glow engine **or**
- 4-stroke .70-.91 glow engine **or**
- 50-55-500 kV outrunner brushless motor, 60A brushless ESC (min) & (2) 11.1V 3200mAh 20C LiPo batteries

The Reactor Biplane .61 GP/EP ARF builds upon the Reactor's reputation for classic lines and a wide flight envelope. It's larger than the Reactor Bipe EP, with the capability for smooth sport maneuvers, pattern flight and 3D aerobatics with an outrunner brushless motor as well as a 2-stroke or 4-stroke glow engine. Quality construction is evident in the fiberglass cowl, wheel pants and upper wing mounting pylon. The wing pylon is glued in place, with the servo leads inside for a cleaner look. Large, airfoiled tail surfaces offer smooth flight and confident control. Pre-hinged ailerons speed final assembly even more. The servo mount cutouts are sized for digital "mini" servos, or can be enlarged to accommodate standard size servos.

## O.S.® Engines .46 AX ABL OSMG0547

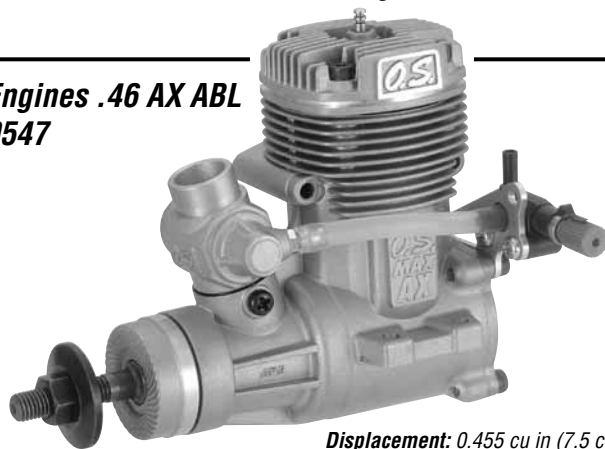

Ask the pilot who owns one, and the reasons to buy mount up fast. Start with 1.65 hp output from a 17.2 oz. engine. Add ABL (Advanced Bimetallic Liner) durability, a self-leveling and aligning head design, a tapered low-speed needle to eliminate transition "surge" and the .46 AX still has more to offer. There's a simple rotor guide screw for low-end adjustment - and the high-speed needle includes both a ratchet spring and O-ring seal to lock settings in for the long haul. Includes A3 glow plug, E-3010 muffler, and 2-year warranty protection.

**Displacement:** 0.455 cu in (7.5 cc) **Output:** 1.65 bhp @16,000 rpm **Includes:** #A3 glow plug, E-3010 muffler  
**Bore:** 0.866 in (22.0 mm) **RPM Range:** 2,000-17,000 **Requires:** glow fuel, prop  
**Stroke:** 0.772 in (19.6 mm) **Weight w/muffler:** 17.2 oz (489g) **Suggested prop sizes:** 10.5x6, 11x6-8, 12x6-7

This model belongs to:

Name

Address

City, State Zip

Phone number

AMA number

Please fill in this identification tag and place inside your model.

## ElectriFly™ RimFire™ .46 Outrunner Brushless Motor GPMG4725

Compared to brushed motors, RimFire motors last longer, require far less maintenance and deliver far more performance. The RimFire .46 outrunner arrives ready for installation, with gold-plated bullet connectors compatible with ElectriFly's BL and Silver Series ESCs. Recommended for 3D airplanes up to 5 lb (2210 g) and sport planes up to 7.5 lb (3400 g); ideal for use with 60A brushless ESCs, 22.2V LiPo packs and 10x5 to 11x5 electric props.



**Diameter:** 1.7 in (42 mm) **Burst Watts:** 1850 **Input:** 18.5-22.2V (5-6S LiPo)  
**Length:** 2.4 in (60 mm) **Weight:** 9.5 oz (268 g) **Includes:** Motor, mount, prop adapter, hardware & gold-plated bullet connectors. (Female connectors are included; male connectors are installed.)  
**kV:** 800 **Shaft Diameter:** 5 mm

**BRUSHLESS COOLING  
HOLE TEMPLATES**

